

# iC-OV

## 5-BIT OPTO ENCODER



### FEATURES

- ◆ High synchronism and technical reliability due to monolithic construction plus integrated photodiodes
- ◆ Short track pitch (600  $\mu\text{m}$ )
- ◆ Scanning with constant-light evaluation
- ◆ Photoelectric amplifier with high cut-off frequency
- ◆ Current comparators with hysteresis
- ◆ Current-limited TTL-compatible push-pull outputs
- ◆ Adjustable LED current control for constant receive power
- ◆ Integrated 40mA driver for the LED
- ◆ Integrated test aid
- ◆ Output of track 1 can be inverted to change the counting direction during Gray Code scanning
- ◆ Overtemperature circuit-breaker with hysteresis
- ◆ Detection and fault message when the safe operating range is exceeded, as the result of undervoltage, over-temperature or an LED current outside the control range
- ◆ Low power consumption

### APPLICATIONS

- ◆ Scanning with constant-light evaluation in absolute and multiturn rotary encoders

### CHIP

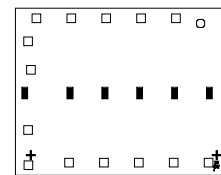

3.6mm x 2.9mm

### BLOCK DIAGRAM

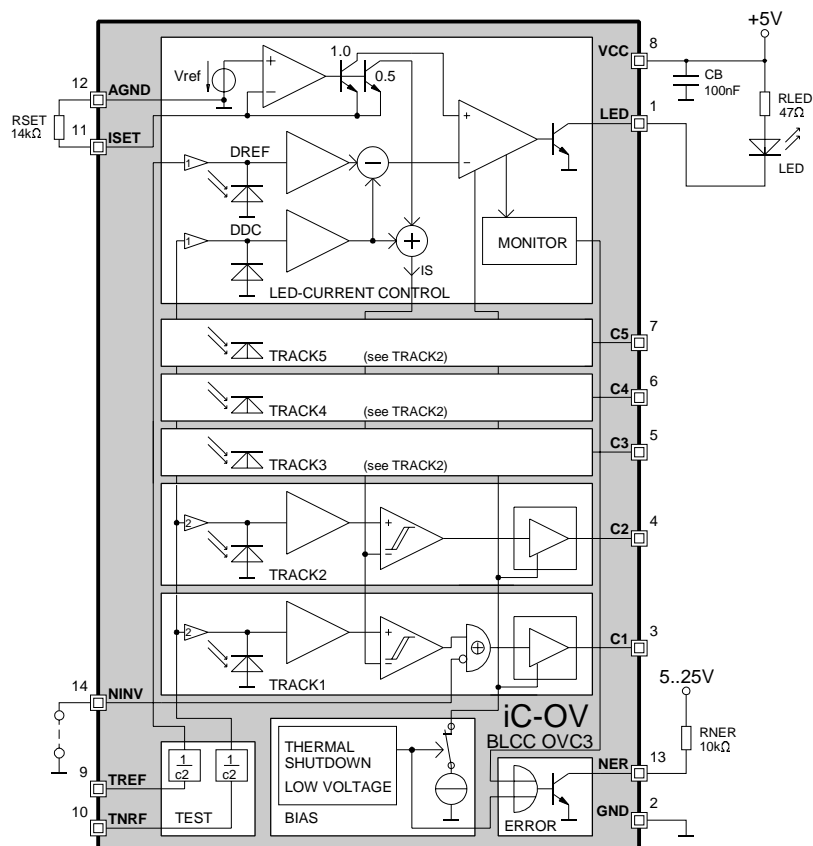

© 2000

Rev C0

# iC-OV

## 5-BIT OPTO ENCODER



Rev C0, 2/9

### DESCRIPTION

The device iC-OV is an optoelectronic encoder IC for absolute linear or angle measuring systems, e.g. glass scales or rotary encoders.

Photodiodes, amplifiers, comparators and TTL-compatible push-pull output drivers for 5 tracks are monolithically integrated, as well as a reference photodiode to control the LED current. The track pitch is 600  $\mu\text{m}$ .

The outputs switch to high when the amplified photoelectric currents exceed a preset threshold (constant-light evaluation). The operating point is determined by an external resistor at RSET.

This resistor also establishes the setpoint for the LED current control. The control keeps the optical receive power constant, irrespective of the temperature or the effects of ageing. The driver stage of the LED current control makes it possible to connect an LED with series resistor directly.

A monitoring circuit generates a fault message in the event of undervoltage, overtemperature or violation of the LED current control range. The fault message output is busable (open collector) and low active.

Two test pins permit a complete function test (without photodiodes).

All inputs and outputs are protected against destruction by ESD. The outputs are short-circuit-proof and are switched off in case of thermal overload.

# iC-OV

## 5-BIT OPTO ENCODER



Rev C0, Page 3/9

### CHIP LAYOUT

dimensions in  $\mu\text{m}$ ; chip size 3.6mm x 2.9mm

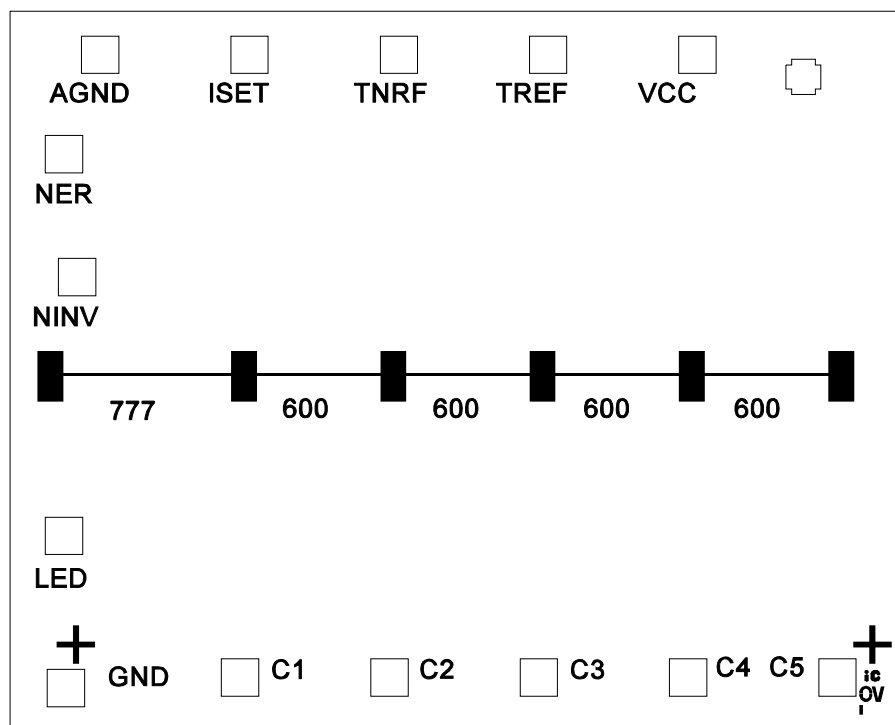

### PAD DESCRIPTION

Name	Function
LED	LED Current Control Output
GND	Ground
C1	Track 1 Push-Pull Output
C2	Track 2 Push-Pull Output
C3	Track 3 Push-Pull Output
C4	Track 4 Push-Pull Output
C5	Track 5 Push-Pull Output
VCC	+5V Supply Voltage
TREF	Test Aid for photodiode DREF
TNRF	Test Aid for tracks 1 to 5 and compensation DDC
ISET	LED Current Control Setup
AGND	Reference Ground for ISET circuitry
NER	Error Message Output, low active
NINV	Track 1 Invert Mode Input, low active

# iC-OV

## 5-BIT OPTO ENCODER



Rev C0, Page 4/9

### ABSOLUTE MAXIMUM RATINGS

Values beyond which damage may occur; device operation is not guaranteed.

Item	Symbol	Parameter	Conditions	Fig.			Unit
					Min.	Max.	
G001	VCC	Supply Voltage			0	7	V
G002	V(C)	Voltage at Outputs C1..5			0	VCC	V
G003	I(C)	Current in Outputs C1..5	V(C) < 0V or V(C) > VCC		-3	3	mA
G004	I(TNRF)	Current in TNRF			-2	1	mA
G005	I(TREF)	Current in TREF			-2	1	mA
G006	I(ISET)	Current in ISET			-2	2	mA
G007	I(AGND)	Current in AGND			-5	5	mA
G008	I(LED)	Current in LED to GND			0	50	mA
G009	I(LED)	Current in LED	V(LED) > VCC		0	3	mA
G010	V(NER)	Voltage at NER			0	30	V
G011	I(NINV)	Current in NINV			-2	2	mA
TG1	Tj	Junction Temperature			-30	125	°C
TG2	Ts	Storage Temperature	see package specification				

### THERMAL DATA

Operating Conditions: VCC= 5V ±10%

Item	Symbol	Parameter	Conditions	Fig.				Unit
					Min.	Typ.	Max.	
T1	Ta	Operating Ambient Temperature Range	see package specification					

All voltages are referenced to ground unless otherwise noted.

All currents into the device pins are positive; all currents out of the device pins are negative.

# iC-OV

## 5-BIT OPTO ENCODER



Rev C0, Page 5/9

### ELECTRICAL CHARACTERISTICS

Operating Conditions:  
VCC= 5V ±10%, Tj= -25..125°C, unless otherwise noted

Item	Symbol	Parameter	Conditions	Tj °C	Fig.				Unit
						Min.	Typ.	Max.	
<b>Total Device</b>									
001	VCC	Permissible Supply Voltage Range				4.5		5.5	V
002	I(VCC)	Supply Current in VCC, Outputs C1..5 hi	closed LED Control: R(ISET/AGND)= 14kΩ, I(LED)≈ 10mA, NER= hi; I(C1..5)= 0, I(D1..5)= 80nA				7	13	mA
003	I(VCC)	Supply Current in VCC, Outputs C1..5 lo	closed LED Control: R(ISET/AGND)= 14kΩ, I(LED)≈ 10mA, NER= hi; I(C1..5)= 0, I(D1..5)≤ 8nA				8	15	mA
004	fo	Cut-off Frequency, tracks 1..5	sinusoidal waveform, I(D1..5)= 8..80nA, I(DREF)= 80nA			200			kHz
005	Δtp()	Delay Skew C1..5	rectangular waveform, I(D1..5)= 8..80nA, I(DREF)= 80nA					0.5	μs
<b>Photodiodes D1..5, DREF</b>									
006	S(λ)max	Spectral Sensitivity	λ= 850nm				0.5		A/W
007	λar	Spectral Application Range	Se(λar)= 0.1×S(λ)max			500		1050	nm
<b>Photodiodes D1..5 with Amplifiers</b>									
101	Aph(D)	Radiant Sensitive Area				0.2 × 0.1			mm²
102	CM()	Common Mode referred to Reference Photodiode DREF				0.85	1	1.15	
<b>Difference Comparators, tracks 1..5</b>									
201	Hys	Hysteresis referred to  I(D) + IS  /2	I(D1..5)= 0..80nA			8	12	16	%
<b>Push-Pull Outputs C1..5</b>									
301	Vs()hi	Saturation Voltage hi	Vs()hi= VCC-V(C); I()= -1.6mA	27			1.1	1.4	V V
302	Vs()lo	Saturation Voltage lo	I()= 1.6mA	-25 27 85 125			0.25	0.4 0.4 0.4 0.5	V V V V
303	Isc()hi	Short-Circuit Current hi	V()= 0..2.8V	27			4	9	mA mA
304	Isc()lo	Short-Circuit Current lo	V()= 2V..VCC	27			5	10	mA mA
305	tr()	Rise Time	C: lo-hi; CL= 30pF				80	260	ns
306	tf()	Fall Time	C: hi-lo; CL= 30pF				40	100	ns
307	Vc()hi	Clamp Voltage hi	Vc()hi= V(C)-VCC; I()= 3mA			0.4		1.5	V
308	Vc()lo	Clamp Spannung lo	I()= -3mA			-1.5		-0.4	V
<b>Test Aid TNRF, TREF</b>									
401	CR()	Current Ratio I(TNRF)/I(D1..5)	test aid active, I()= 2..200μA			200	550	800	
402	CR()	Current Ratio I(TNRF)/I(DDC), I(TREF)/I(DREF)	test aid active, I()= 2..200μA			400	1100	1600	

# iC-OV

## 5-BIT OPTO ENCODER



Rev C0, Page 6/9

### ELECTRICAL CHARACTERISTICS

Operating Conditions:  
VCC= 5V ±10%, Tj= -25..125°C, unless otherwise noted

Item	Symbol	Parameter	Conditions	Tj °C	Fig.				Unit
						Min.	Typ.	Max.	
<b>Test Aid TNRF, TREF (continued)</b>									
403	I <sub>t</sub> ( <i>)</i>	Pull-Down Current (Test Aid Turn-on Threshold)	V( <i>)</i> = 0.5V	-25 27 85 125		2	14 17 21 23	150	μA μA μA μA
404	V( <i>)</i> <sub>on</sub>	Turn-on Voltage	test aid active; I(TNRF)= 2..200μA and I(TREF)= 100μA, or I(TNRF)= 100μA and I(TREF)= 2..200μA	-25 27 85 125		1.9 1.6 1.3 1.1	2.4 2.1 1.8 1.6	2.7 2.4 2.1 1.9	V V V V
<b>LED Current Control with Reference Photodiode DREF</b>									
501	A <sub>ph</sub> ( <i>)</i>	Radiant Sensitive Area DREF				0.2 × 0.1			mm <sup>2</sup>
502	I(DREF)	Permis. Photocurrent at DREF				10		200	nA
503	I(LED)	Permis. Driver Current in LED				0		40	mA
504	V <sub>s</sub> (LED)	Saturation Voltage at LED	I(LED)= 40mA, I(ISET)>10μA, I(DREF)=0			0.4	0.9	1.4	V
505	V(ISET)	Voltage at ISET	I(ISET)= -100..-10μA			1.14	1.22	1.28	V
506	I <sub>sc</sub> ( <i>)</i>	Short-Circuit Current in ISET	V(ISET)= 0	27			0.5	1.3	mA mA
507	CR( <i>)</i>	Current Ratio I(ISET)/I(DREF)	closed LED control, I(DREF)= 20..200nA			720	1080	1820	
508	CR( <i>)</i>	Current Ratio I(ISET)/I(DREF)	closed LED control, I(DREF)= 60..120nA			840	1080	1440	
509	V <sub>c</sub> ( <i>)<sub>hi</sub></i>	Clamp Voltage hi at ISET, LED	VCC= 0, I( <i>)</i> = 3mA			0.4		1.5	V
510	V <sub>c</sub> ( <i>)<sub>lo</sub></i>	Clamp Voltage lo at ISET, LED	VCC= 0, I( <i>)</i> = -3mA			-1.5		-0.4	V
<b>Inverting Mode Input NINV</b>									
601	V <sub>t</sub> ( <i>)</i>	Threshold Voltage hi				0.5		1	V
602	I <sub>pu</sub> ( <i>)</i>	Pull-Up Current	V(NINV)= 0V, I(D1)< I(DREF)				80		μA
603	I <sub>pu</sub> ( <i>)</i>	Pull-Up Current	V(NINV)= 0V, I(D1)> I(DREF)				20		μA
604	V <sub>c</sub> ( <i>)<sub>hi</sub></i>	Clamp Voltage hi	V <sub>c</sub> ( <i>)<sub>hi</sub>= V(NINV)-VCC; I(<i>)</i>= 3mA</i>			0.4		1.5	V
605	V <sub>c</sub> ( <i>)<sub>lo</sub></i>	Clamp Voltage lo	I( <i>)</i> = -3mA			-1.5		-0.4	V
<b>Bias, Temperature and Supply Monitor</b>									
701	T <sub>off</sub>	Thermal Shutdown Threshold				127	138	150	°C
702	Th <sub>ys</sub>	Thermal Shutdown Hysteresis	Th <sub>ys</sub> = T <sub>off</sub> -T <sub>on</sub>			5	9	12	°C
703	VCC <sub>on</sub>	Turn-on Threshold VCC				3.6	3.9	4.4	V
704	VCC <sub>off</sub>	Undervoltage Threshold at VCC	decreasing Supply VCC			3.4	3.8	4.3	V
705	VCC <sub>hys</sub>	Hysteresis	VCC <sub>hys</sub> = VCC <sub>on</sub> -VCC <sub>off</sub>			40	100	250	mV
706	V <sub>s</sub> (NER)	Saturation Voltage lo at NER	I( <i>)</i> = 1.6mA	-25 27 85 125			0.3	0.4 0.4 0.4 0.5	V V V V
707	I <sub>sc</sub> (NER)	Short-Circuit Current lo in NER	V( <i>)</i> = 2V..VCC	27			5	8	mA mA
708	I <sub>0</sub> (NER)	Collector Off-State Current in NER	NER: off, V( <i>)</i> = 25V	27			0.1	10	μA μA

**DESCRIPTION OF FUNCTIONS**

**LED Current Control**

The integrated LED current control with driver stage keeps the photoelectric current of the reference photodiode DREF constant. This compensates for ageing, dirt and the decline in LED efficiency as the temperature rises.

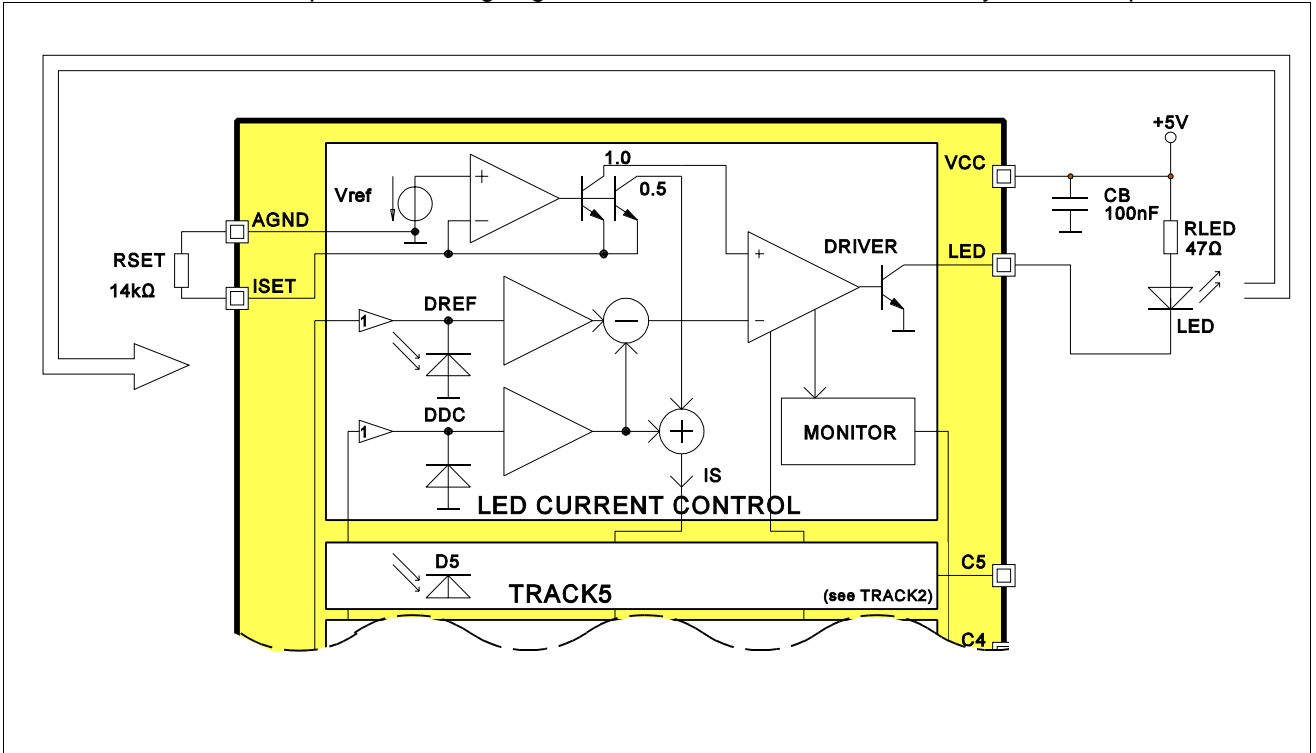

Fig. 1: LED Current Control and Monitor

The photoelectric current of the reference DREF and the dark current of compensation diode DDC are amplified in the current control. The amplified currents are subtracted from one another, yielding the actual value for the driver's negative input to trigger the LED.

At the same time, resistor RSET at the pin ISET sets the setpoint for the positive input of the driver - the voltage at pin ISET is kept at a constant approx. 1.22V.

If there is an optical feedback loop from the LED to reference photodiode DREF, the driver changes the current through the LED until the actual value at the negative input corresponds to the setpoint at the positive input.

The photoelectric current through the reference DREF and, therefore, the illuminance for the system as a whole are kept constant. A monitor circuit detects the violation of the control range and indicates this via the fault message circuit (block: Error).

The series resistor RLED connected in series to the LED limits the current through the diode and establishes the operating limit of the control.

The optical feedback between LED and reference photodiode should suffice to yield an LED current of less than 8mA at room temperature. The power driver then also possesses sufficient current reserve to correct the dropping efficiency of the LED at high temperatures.

### Tracks 1..5

The threshold  $I_S$  of the current comparators for tracks C1 to C5 is determined by the resistor RSET and is about  $0.5 \times ISET$ . The threshold is supplemented by the amplified current of compensation diode DDC to compensate for the dark currents of photodiodes D1 to D5 and the amplifier input currents. The hysteresis of the current comparators enhances the interference immunity.

Track 1 can be inverted by connecting pin NINV to ground (GND). If the pin remains open, the internal pull-up current source generates a high level. When the Gray Code is used, inverting the MSB track is the equivalent to reversing the movement.

### Fault message in case of overtemperature or undervoltage

When the chip temperature is too high or the voltage too low, the push-pull output stages are switched to a high-impedance state and the error state is signalled to the message circuit (block: Error). Both monitoring circuits operate with hysteresis;  $NER = \text{low}$  remains until the cause of the error has been eliminated.

Violating the limits of the LED current control range also generates a low signal at the open collector output NER.

## APPLICATIONS INFORMATION

### Wiring the Test Aid

To activate the test aid integrated into the iC-OV, the current threshold defined in the Electrical Characteristics No. 403 must be exceeded at both pins TREF and TNRF. This activates the testing aid which does not switch back off until the current drops below approx.  $1 \mu\text{A}$ .

A clamping circuit as per Fig. 2 also prevents a brief drop below the cut-off threshold. A changeover switch can be used to reverse the output polarity of the iC-OV.

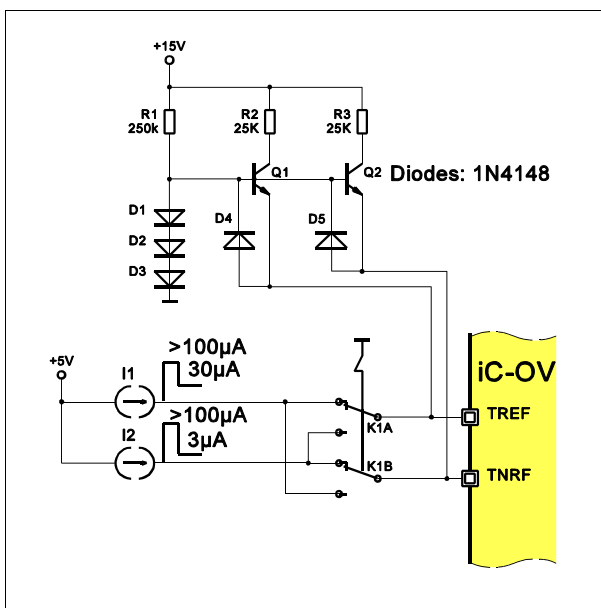

Fig. 2: Wiring the testing aid

# iC-OV

## 5-BIT OPTO ENCODER



Rev C0, Page 9/9

### ORDERING INFORMATION

Type	Package	Order designation
iC-OV		iC-OV Chip
iC-OV	BLCC OVC3	iC-OV BLCC OVC3

For information about prices, terms of delivery, options for other case types, etc., please contact:

**iC-Haus GmbH**  
**Am Kuemmerling 18**  
**D-55294 Bodenheim**  
**GERMANY**

**Tel (+49)6135-9292-0**  
**Fax (+49)6135-9292-192**  
**<http://www.ichaus.com>**

This specification is for a newly developed product. iC-Haus therefore reserves the right to modify data without further notice. Please contact us to ascertain the current data. The data specified is intended solely for the purpose of product description and is not to be deemed guaranteed in a legal sense. Any claims for damage against us - regardless of the legal basis - are excluded unless we are guilty of premeditation or gross negligence.

We do not assume any guarantee that the specified circuits or procedures are free of copyrights of third parties.

Copying - even as an excerpt - is only permitted with the approval of the publisher and precise reference to source.