

# iC-TW4

## 8-BIT SIN/COS INTERPOLATOR WITH AUTOMATIC OFFSET CORRECTION

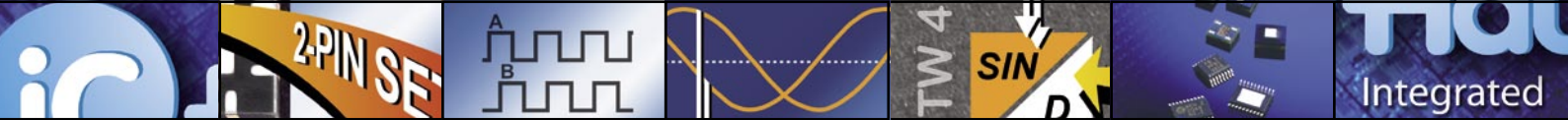
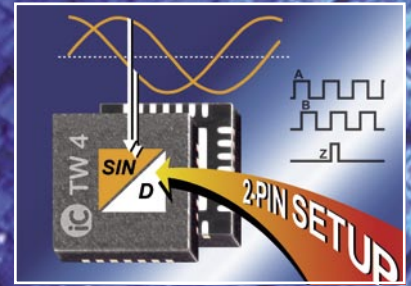

The iC-TW4 is a configurable low cost interpolation and signal conditioning device featuring encoder quadrature output signals. The chip is pin configured with four resistors and needs no microcontroller or EEPROM for operation or configuration. The chip operates on single-sided supplies of 3.3 V to 5 V.

The interpolation engine interfaces differential sensor bridges with no external components required. The automatic offset compensation eliminates sensor and input amplifier offsets. There is no system calibration needed.

### Applications

- Optical and magnetic position sensors
- Rotary encoders
- Linear encoders
- Small and simple embedded solutions

### Features

- Programmable real-time interpolation
- Selectable interpolation factors of x2, x4, x5, x8, x10, x16, x20, x25, x32, x50, x64
- Differential inputs for current and voltage signals
- Selectable gain (10 mV to 1.5 V and 2.5  $\mu$ A to 20  $\mu$ A)
- Maximum input frequency of up to 300 kHz (x2 to x8), 150 kHz (x10 to x16), 75 kHz (> x20)
- Encoder quadrature output signals
- Startup behaviour: ABZ to absolute position in period
- Differential output drivers for 120  $\Omega$  termination
- Latency < 1  $\mu$ s
- Hysteresis selectable from 2.8° to 15.6°
- Filter of 16 samples
- Single supply of 3.3 V and 5 V, low power consumption
- Static pin programming via four external resistors
- Automatic offset correction of sensor and interpolator offset
- Extended temperature range -40 °C to +125 °C

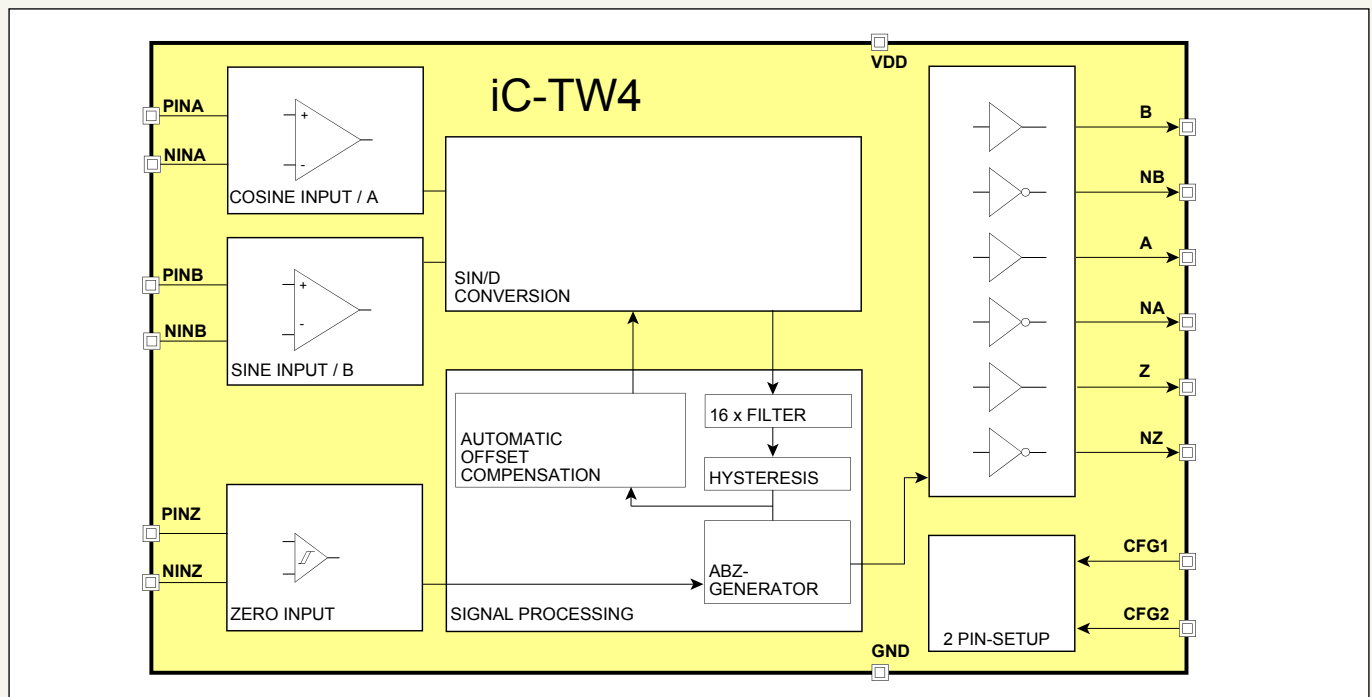

# iC-TW4 8-BIT SIN/COS INTERPOLATOR WITH AUTOMATIC OFFSET CORRECTION

iC-TW4 supports also single-ended sensor signals by tying the negative input terminal to the signal reference, usually Vdd/2.

The iC-TW4 can interface a wide range of index gating sources e.g. Hall or MR sensors. The device generates a single index pulse for every period from the SIN/COS signals that is gated by the index signal.

A built in Power-On-Reset circuit keeps the device in reset until the applied power supply voltage allows reliable operation.

## Pin Functions

No.	Name	Pin Function
1	n.c.	n.c.
2	NZ	Index Output Z-
3	B	Quadrature Output B+
4	NB	Quadrature Output B-
5	A	Quadrature Output A+
6	n.c.	n.c.
7	n.c.	n.c.
8	NA	Quadrature Output A-
9	GND	Ground
10	CFG1	Configuration Pin 1
11	CFG2	Configuration Pin 2
12	n.c.	n.c.
13	n.c.	n.c.
14	PINB	Pos. Signal Input Channel B (cosine)
15	NINB	Neg. Signal Input Channel B (cosine)
16	NINA	Pos. Signal Input Channel A (sine)
17	PINA	Neg. Signal Input Channel A (sine)
18	n.c.	n.c.
19	n.c.	n.c.
20	PINZ	Pos. Index Enable Input
21	NINZ	Neg. Index Enable Input
22	VDD	+3.3 to 5 V Power Supply
23	Z	Index Output Z+
24	n.c.	n.c.

## Pin Configuration QFN24 4 mm x 4 mm

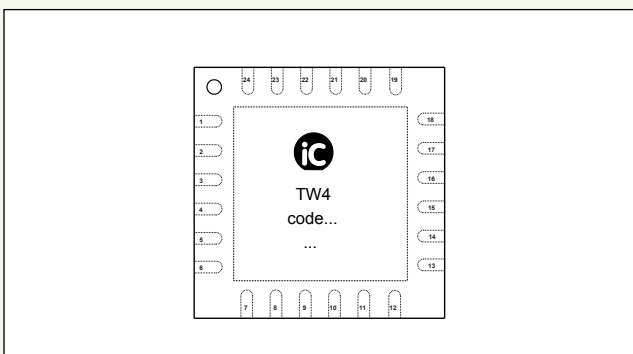

## Key Specifications

### Inputs and Signal Conditioning

Permissible Input Frequency	300 kHz: x2, x4, x5, x8; 150 kHz: x10, x16; 75 kHz: x20, x25, x32, x50, x64
-----------------------------	---

### Input Signal Range Configuration (Gain)

Input Signal Amplitude	Permissible Input Signal Offset
800 mV to 1.5 V	± 400 mV
400 mV to 800 mV	± 232 mV
200 mV to 400 mV	± 112 mV
100 mV to 200 mV	± 50 mV
50 mV to 100 mV	± 19 mV
10 mV to 50 mV	± 3.5 mV

Configuration Resistors with max. 1 % tolerance

### Sine-to-Digital Conversion

Angle Resolutions	8 to 256 steps/period
Interpolation Factors	x2, x4, x5, x8, x10, x16, x20, 25, x32, x50, x64
Absolute Angle Accuracy	± 5°
Angle Hysteresis	x2 to x16: 10.4°, 15.6°; x20, x25: 5.6°, 10.4°; x32, x50: 2.8°, 5.6°; x64: 2.8°, 5.6°
Input-To-Output Latency	< 1 µs

### Incremental Outputs

Output Signals	A, B and gated index Z
Output Characteristics	TTL/CMOS compatible, +/- 6 mA, tr/tf 4 ns @ 3.3 V and CL 10 pF
Index Output Modes	calibration mode for sensor variation compensation gated with A and B

### Other Operational Data

Supply Voltage	single 3.3 to 5 V supply
Operational Temp. Range	-40 °C to +125 °C
On-Chip Clock	typ. 21 MHz @ 5 V, 25 °C
On-Chip Clock Variation	20 %, -40 °C to +125 °C
Package	QFN24 (4 mm x 4 mm) or Dice

## Application Example

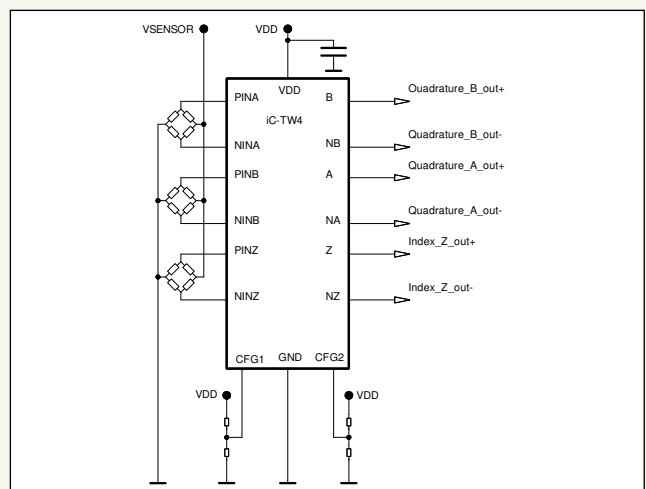

This tentative information shall not be considered as a guarantee of characteristics. Rights to technical changes reserved.