

iC-PN2656

PHASED ARRAY NONIUS ENCODER 26-256

FEATURES

- ◆ Compact photosensor for high-resolution Nonius scanning
- ◆ Phased-array design for excellent signal matching
- ◆ Reduced cross talk due to moderate track pitch
- ◆ Ultra low dark currents for operation to high temperature
- ◆ Low noise amplifiers with high transimpedance of typ. 4 M Ω
- ◆ Short-circuit-proof, low impedance voltage outputs for enhanced EMI tolerance
- ◆ Space saving QFN and optoBGA packages (RoHS compliant)
- ◆ Low power consumption from single 4.5 to 5.5 V supply
- ◆ Operational temperature range of -40 to +125 °C
- ◆ Available code discs with 255/256/240 PPR
 - LSHC4S 26-256N (OD/ID \varnothing 26/11.6 mm, glass)
 - LSHC5S 26-256N (OD/ID \varnothing 26/7 mm, plastic)

APPLICATIONS

- ◆ Absolute position encoders

PACKAGES

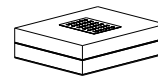

32-pin QFN
15-pin optoBGA

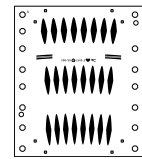

Chip
2.88 mm x 3.37 mm

BLOCK DIAGRAM

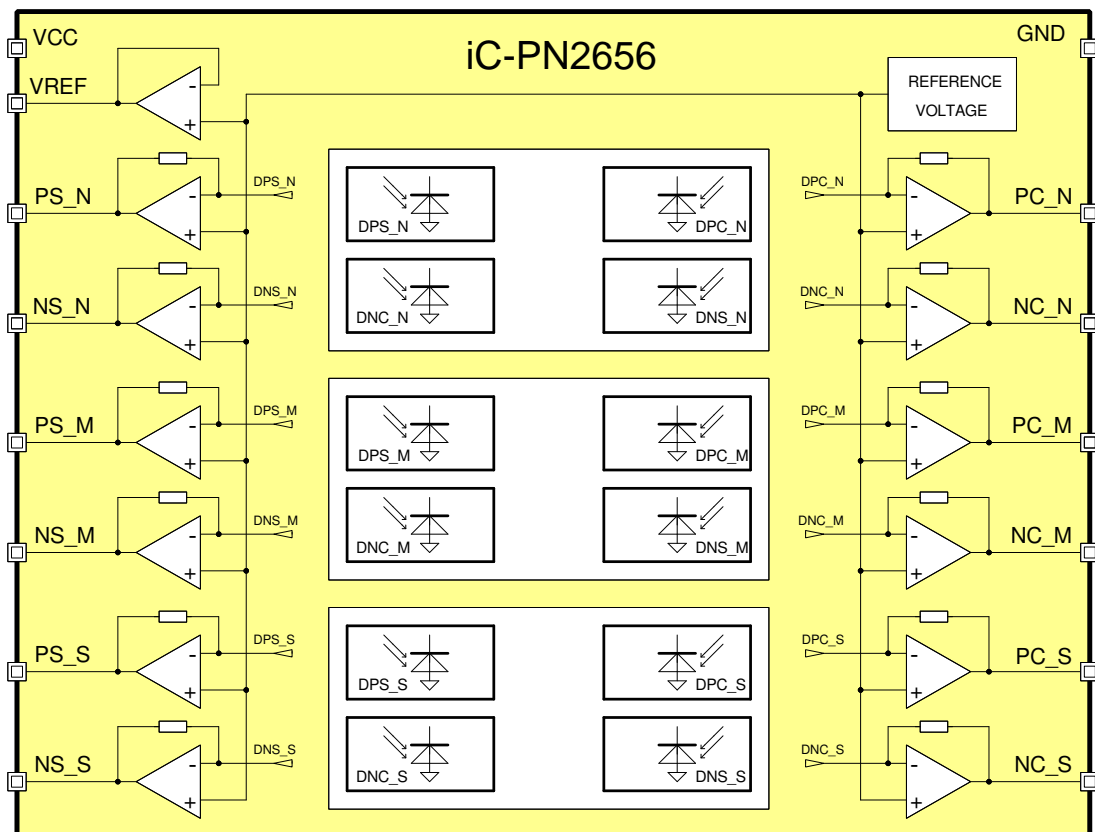

iC-PN2656

PHASED ARRAY NONIUS ENCODER 26-256

DESCRIPTION

The phased-array iC-PN2656 features 24 monolithically integrated photosensors with active areas of $800\ \mu\text{m} \times 330\ \mu\text{m}$ each. A high transimpedance gain of typically $4\ \text{M}\Omega$ generates output signals of a few hundred Millivolts already from illumination levels of 0.1 to $0.2\ \text{mW}/\text{cm}^2$. In most cases no additional measures must be considered to filter for noise and interferences.

Analog nonius encoders are the typical application for iC-PN2656. Its 3-track scanning features a phased-array of 8 photosensors each per track, generating positive and negative going sine signals, as well as positive and negative going cosine signals.

An excellent matching and common mode behavior of the differential signal paths is obtained by a paired amplifier design, reducing the needs for external signal calibration to an absolute minimum.

The spectral sensitivity range includes visible to near infrared light, with the maximum sensitivity being close to a wavelength of $680\ \text{nm}$. An output voltage of approximately $1\ \text{V}$ is typical under low light conditions, for instance when iC-PN2656 is illuminated at only $2\ \mu\text{W}/\text{mm}^2$ by an $740\ \text{nm}$ LED. A threefold intensity is sufficient when using iC-PN2656 for encoder applications with typical disc and mask codes.

PACKAGES INFORMATION

PAD LAYOUT (2.88 mm x 3.37 mm)

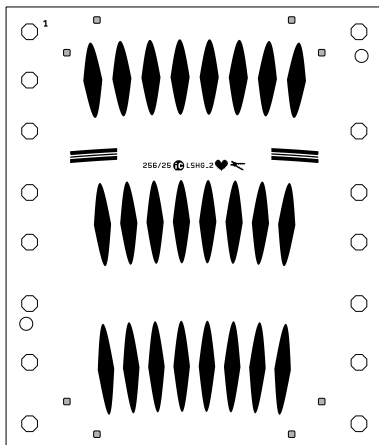

PAD FUNCTIONS

No. Name Function

1	VCC	+4.5..5.5 V Supply Voltage
2	VREF	Reference Voltage Output
3	PS_N	N-Track Sine +
4	NS_N	N-Track Sine -
5	PS_M	M-Track Sine +
6	NS_M	M-Track Sine -
7	PS_S	S-Track Sine +
8	NS_S	S-Track Sine -
9	NC_S	S-Track Cosine -
10	PC_S	S-Track Cosine +
11	NC_M	M-Track Cosine -
12	PC_M	M-Track Cosine +
13	NC_N	N-Track Cosine -
14	PC_N	N-Track Cosine +
15	GND	Ground

All outputs are analog voltage outputs.

iC-PN2656

PHASED ARRAY NONIUS ENCODER 26-256

preliminary



Rev A4, Page 3/7

PIN CONFIGURATION

cQFN32 (5 mm x 5 mm),

oQFN32 (5 mm x 5 mm)

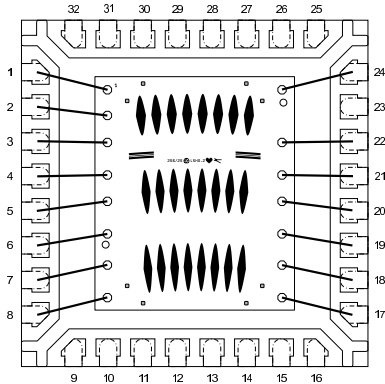

PIN FUNCTIONS

No. Name Function

1	VCC	+4.5..5.5 V Supply Voltage
2	VREF	Reference Voltage Output
3	PS_N	N-Track Sine +
4	NS_N	N-Track Sine -
5	PS_M	M-Track Sine +
6	NS_M	M-Track Sine -
7	PS_S	S-Track Sine +
8	NS_S	S-Track Sine -
9	NC_S	S-Track Cosine -
10	PC_S	S-Track Cosine +
11	NC_M	M-Track Cosine -
12	PC_M	M-Track Cosine +
13	NC_N	N-Track Cosine -
14	PC_N	N-Track Cosine +
15	GND	Ground

PIN CONFIGURATION

oBGA LSH2C (6.2 mm x 5.2 mm)

1 2 3 4

A
B
C
D

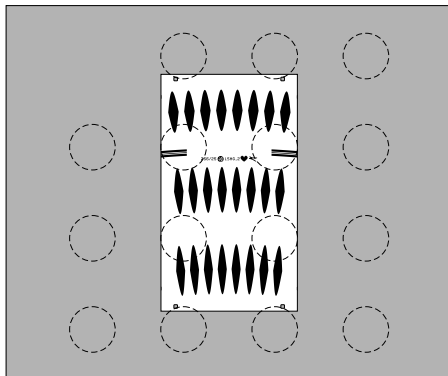

PIN FUNCTIONS

No. Name Function

A2	VCC	+4.5..5.5 V Supply Voltage
A3	VREF	Reference Voltage Output
A4	GND	Ground
B1	PS_N	N-Track Sine +
B2	NS_N	N-Track Sine -
B3	NC_N	N-Track Cosine -
B4	PC_N	N-Track Cosine +
C1	PS_M	M-Track Sine +
C2	NS_M	M-Track Sine -
C3	NC_M	M-Track Cosine -
C4	PC_M	M-Track Cosine +
D1	PS_S	S-Track Sine +
D2	NS_S	S-Track Sine -
D3	NC_S	S-Track Cosine -
D4	PC_S	S-Track Cosine +

ABSOLUTE MAXIMUM RATINGS

These ratings do not imply operating conditions; functional operation is not guaranteed. Beyond these ratings device damage may occur.

Item No.	Symbol	Parameter	Conditions			Unit
				Min.	Max.	
G001	VCC	Voltage at VCC		-0.3	6	V
G002	I(VCC)	Current in VCC		-20	20	mA
G003	V()	Pin Voltage, all signal outputs		-0.3	VCC + 0.3	V
G004	I()	Pin Current, all signal outputs		-20	20	mA
G005	Vd()	ESD Susceptibility, all pins	HBM, 100 pF discharged through 1.5 kΩ		2	kV
G006	Tj	Junction Temperature		-40	150	°C
G007	Ts	Chip Storage Temperature		-40	150	°C

THERMAL DATA

Item No.	Symbol	Parameter	Conditions	Min.	Typ.	Max.	Unit
T01	Ta	Operating Ambient Temperature Range	package cQFN32 (clear) package oQFN32 (black) package oBGA LSH2C	-20 -40 -40		70 110* 125	°C °C °C
T02	Ts	Storage Temperature Range	package cQFN32 (clear) package oQFN32 (black) package oBGA LSH2C	-20 -40 -40		70 110* 125	°C °C °C
T03	Tpk	Soldering Peak Temperature	package cQFN32 (clear) tpk < 10 s, convection reflow MSL 5A (max. floor live 24 h at 30 °C and 60 % RH) Please refer to customer information file No. 7 for details. Not suitable for vapour phase soldering.			245	°C
T04	Tpk	Soldering Peak Temperature	package cQFN32 (black) tpk < 10 s, convection reflow MSL 3 (max. floor live 168 h at 30 °C and 60 % RH) Please refer to customer information file No. 7 for details. Not suitable for vapour phase soldering.			245*	°C
T05	Tpk	Soldering Peak Temperature	package oQFN32 (black) package oBGA LSH2C tpk < 20 s, convection reflow tpk < 20 s, vapor phase soldering TOL (time on label) 8 h; Please refer to customer information file No. 7 for details.			260 230	°C °C

*) Package qualification pending.

All voltages are referenced to ground unless otherwise stated.

All currents into the device pins are positive; all currents out of the device pins are negative.

ELECTRICAL CHARACTERISTICS

Operating conditions: VCC = 4.5...5.5 V, Tj = -40...125 °C, unless otherwise stated

Item No.	Symbol	Parameter	Conditions	Min.	Typ.	Max.	Unit
Total Device							
001	VCC	Permissible Supply Voltage		4.5		5.5	V
002	I(VCC)	Supply Current	no load, photocurrents within op. range		9.5	15	mA
003	Vc()hi	Clamp-Voltage hi at all pins	I() = 4 mA			11	V
004	Vc()lo	Clamp-Voltage lo at all pins	I() = -4 mA	-1.2		-0.3	V
Photosensors							
101	λ_{ar}	Spectral Application Range	$Se(\lambda_{ar}) = 0.25 \times S(\lambda)_{max}$	400		950	nm
102	λ_{pk}	Peak Sensitivity Wavelength			680		nm
103	Aph()	Radiant Sensitive Area	0.8 mm x 0.33 mm (each sensor)		0.264		mm ²
104	S(λ)	Spectral Sensitivity	$\lambda_{LED} = 740$ nm		0.5		A/W
105	S(λ_{pk})max	Maximum Spectral Sensitivity	$\lambda_{LED} = \lambda_{pk}$		0.55		A/W
106	E()mxr	Permissible Irradiance	$\lambda_{LED} = 740$ nm, Vout() not saturated	0.18	0.37	0.78	mW/cm ²
107	E()mxpk	Permissible Irradiance	$\lambda_{LED} = \lambda_{pk}$, Vout() not saturated	0.16	0.34	0.71	mW/cm ²
Photocurrent Amplifiers							
201	Iph()	Permissible Photocurrent Operating Range		0		280	nA
202	$\eta()$ r	Photo Sensitivity (light-to-voltage conversion ratio)	$\lambda_{LED} = 740$ nm	1.12	2.0	3.28	V/ μ W
203	Z()	Equivalent Transimpedance Gain	$Z = Vout() / Iph()$	2.69	4.0	5.46	M Ω
204	TCz	Temperature Coefficient of Transimpedance Gain			-0.12		%/°C
209	$\Delta Z()$ pn	Transimpedance Gain Matching	P vs. N path per diff. channel	-0.2		0.2	%
210	$\Delta Vout()$ pn	Output Signal Matching	P vs. N path per diff. channel, illumination to E()mxr	-6		6	mV
211	$\Delta Vout()$ pn	Dark Signal Matching	P vs. N path per diff. channel	-2.5		2.5	mV
212	fc()hi	Cut-off Frequency (-3 dB)		220	310	465	kHz
213	VNoise()	RMS Output Noise	illuminated to 500 mV signal level above dark level, 500 kHz band width		0.5		mV
Signal Outputs							
301	Vout()mx	Maximum Output Voltage	illumination to E()mxr	2.45	2.72	3.02	V
302	Vout()d	Dark Signal Level	load 20 k Ω vs. +2V, no illumination	640	770	985	mV
303	Vout()acmx	Maximum Signal Level	$Vout()acmx = Vout()mx - Vout()d$	1.48	1.96	2.35	V
304	Isc()hi	Short-Circuit Current hi	load current to ground	200	540	800	μ A
305	Isc()lo	Short-Circuit Current lo	load current to IC	250	425	600	μ A
306	Ri()	Internal Output Resistance	f = 1 kHz	70	110	180	Ω
Reference Voltage VREF							
401	VREF	Reference Voltage	I(VREF) = 0...-1.6 mA	640	770	985	mV

APPLICATION CIRCUITS

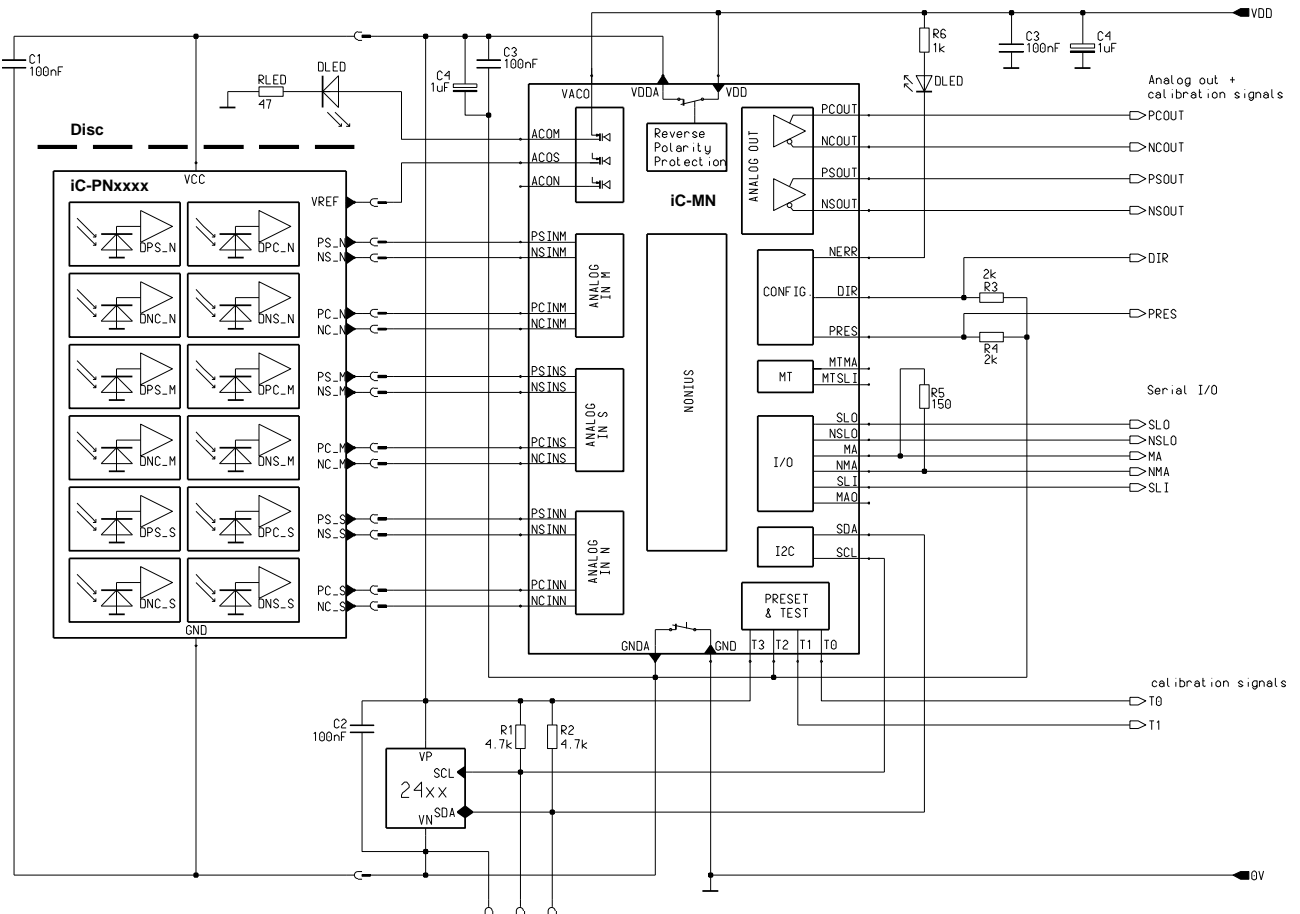

Figure 1: Application example of absolute encoder circuit.

This specification is for a newly developed product. iC-Haus therefore reserves the right to change or update, without notice, any information contained herein, design and specification; and to discontinue or limit production or distribution of any product versions. Please contact iC-Haus to ascertain the current data. Copying – even as an excerpt – is only permitted with iC-Haus approval in writing and precise reference to source.

iC-Haus does not warrant the accuracy, completeness or timeliness of the specification on this site and does not assume liability for any errors or omissions in the materials. The data specified is intended solely for the purpose of product description. No representations or warranties, either express or implied, of merchantability, fitness for a particular purpose or of any other nature are made hereunder with respect to information/specification or the products to which information refers and no guarantee with respect to compliance to the intended use is given. In particular, this also applies to the stated possible applications or areas of applications of the product.

iC-Haus conveys no patent, copyright, mask work right or other trade mark right to this product. iC-Haus assumes no liability for any patent and/or other trade mark rights of a third party resulting from processing or handling of the product and/or any other use of the product.

As a general rule our developments, IPs, principle circuitry and range of Integrated Circuits are suitable and specifically designed for appropriate use in technical applications, such as in devices, systems and any kind of technical equipment, in so far as they do not infringe existing patent rights. In principle the range of use is limitless in a technical sense and refers to the products listed in the inventory of goods compiled for the 2008 and following export trade statistics issued annually by the Bureau of Statistics in Wiesbaden, for example, or to any product in the product catalogue published for the 2007 and following exhibitions in Hanover (Hannover-Messe).

We understand suitable application of our published designs to be state-of-the-art technology which can no longer be classified as inventive under the stipulations of patent law. Our explicit application notes are to be treated only as mere examples of the many possible and extremely advantageous uses our products can be put to.

iC-PN2656

PHASED ARRAY NONIUS ENCODER 26-256

preliminary



Rev A4, Page 7/7

ORDERING INFORMATION

Type	Package	Options	Order Designation
iC-PN2656	- QFN32 5 mm x 5 mm (clear) QFN32 5 mm x 5 mm (black) optoBGA 6.2 mm x 5.2 mm	Encoder discs Nonius code disc 255/256/240 PPR, OD/ID \varnothing 26/11.6 mm, glass Nonius code disc 255/256/240 PPR, OD/ID \varnothing 26/7 mm, plastic	iC-PN2656 chip iC-PN2656 cQFN32 iC-PN2656 oQFN32 iC-PN2656 oBGA LSH2C LSHC4S 26-256N LSHC5S 26-256N

For technical support, information about prices and terms of delivery please contact:

iC-Haus GmbH
Am Kuemmerling 18
D-55294 Bodenheim
GERMANY

Tel.: +49 (61 35) 92 92-0
Fax: +49 (61 35) 92 92-192
Web: <http://www.ichaus.com>
E-Mail: sales@ichaus.com

Appointed local distributors: http://www.ichaus.de/support_distributors.php