

# iC-NZ FAIL-SAFE LASER DIODE DRIVER



The fail-safe, three channel laser switch iC-NZ enables spike-free switching of laser diodes at frequencies ranging from DC to 155 MHz. The output power control of the three channels is adjusted separately by three external resistors (RMH, RMM, RML).

## Applications

- Laser light barriers
- Distance measurement
- Bar-code readers
- Laser projection

## Features

- Peak value controlled threefold laser switch
- Operation from CW up to 155 MHz
- Spike-free switching
- Laser current of 100 mA per channel from 3.5 to 5 V supply voltage
- Single-failure proof with second monitor diode
- System-enable with self test
- Separate setting of laser power for each channel via external resistors
- Strong suppression of transients with very small external capacitors
- Adjustable laser current limitation
- All current LD types can be used (M/P/N configurations)
- Error signal output at shutdown and current limitation

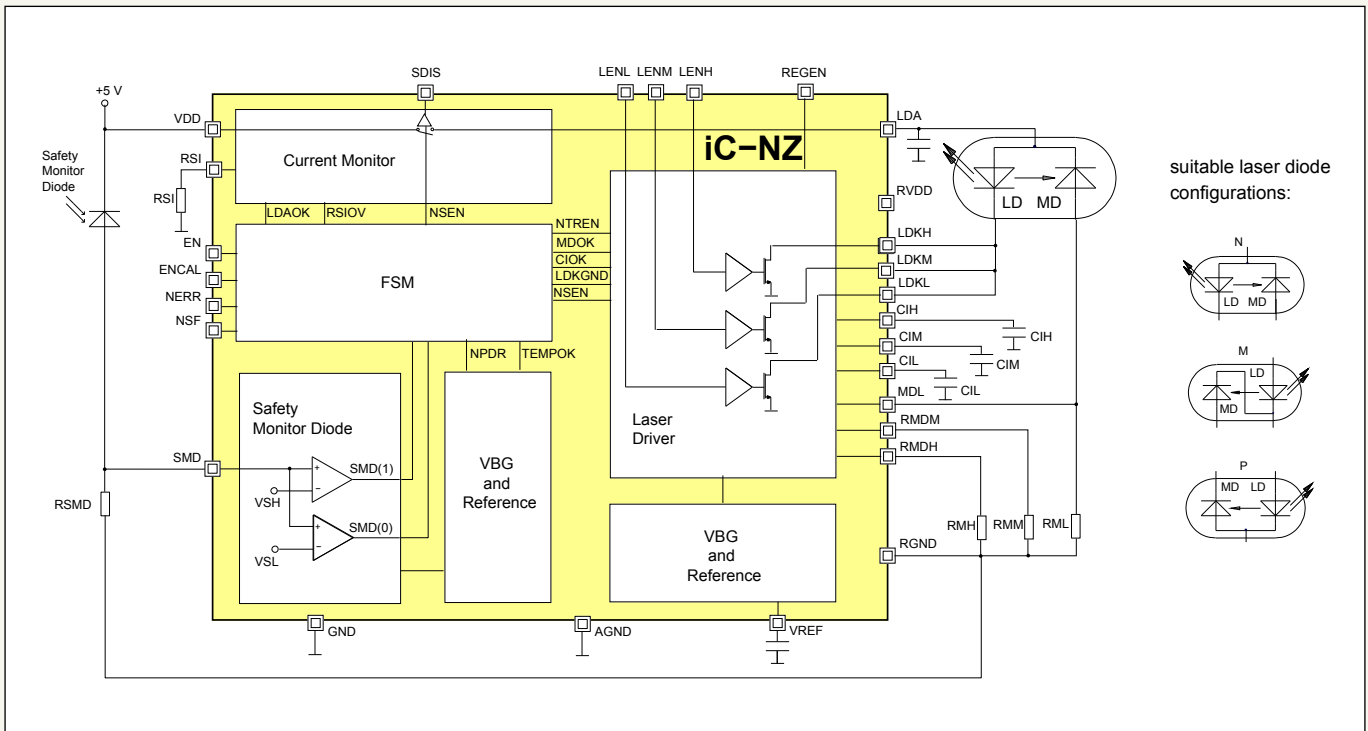



# iC-NZ FAIL-SAFE LASER DIODE DRIVER

System-enable via pin 'EN' starts an initial self test. If no failure is detected, the driver gets enabled. Possible failures are signaled at pin 'NERR'. A cyclic self test permanently checks the system for failures.

The external resistor RSI sets the current limitation (average value). Overcurrent triggers a system shutdown and is signaled at pin 'NERR'.

To ensure that the selected laser class is retained, a second monitor input 'SMD' is required (Safety Monitor Diode). The otherwise optional monitor diode supervises the laser output power. Leaving the monitoring range, adjusted by resistor 'RSMD', also leads to a permanent shutdown. The shutdown is signaled at 'NERR'. The system can only be restarted by cycling 'EN'.

For high switching frequencies pin 'REGEN' enables the 'burst' mode, where a previously adjusted output level is sustained for a certain time.

## Pin Functions

No.	Name	Function
1	RMDH	APC Setup, Monitor Input Hi
2	RVDD	Reference (P-type diodes)
3	RMDM	APC Setup, Monitor Input Mid
4	NSF	No-Safety Signal
5	MDL	APC Setup, Monitor Input Lo
6	ENCAL	Enable Calibration
7	RGND	Internal Ground
8	SMD	Safety Monitor Diode
9	GND	Ground
10	VREF	Reference Voltage
11	CIL	Power Control Capacitor Lo
12	REGEN	Enable Power Control
13	CIM	Power Control Capacitor Mid
14	LENL	Enable Laser Channel Lo
15	LENM	Enable Laser Channel Mid
16	GND	Ground
17	LDKM	Cathode Laser Diode Mid
18	AGND	Analog Ground
19	LDKL	Cathode Laser Diode Lo
20	LDKH	Cathode Laser Diode Hi
21	LENH	Enable Laser Channel Hi
22	NERR	Error Output
23	EN	Enable Input
24	CIH	Power Control Capacitor Hi
25	LDA	Anode Laser Diode
26	RSI	Current Limitation Setup
27	SDIS	External Current Limitation
28	VDD	Power Supply

## Key Specifications

### General

Supply Voltage Range	3.5 to 5.5 V
Monitor Current	up to 2.5 mA
Monitor Current at SMD	up to 5 mA

### Laser Driver

Laser Current I(LDKL)	up to 120 mA
Laser Current I(LDKM)	up to 100 mA
Laser Current I(LDKH)	up to 100 mA
Saturation Voltage at LDKx I(LDKx) = 100 mA I(LDKx) = 60 mA	1.2 V 0.8 V
Laser Current Rise Time	max. 1.5 ns
Laser Current Fall Time	max. 1.5 ns
Laser Current Turn-On Delay	max. 10 ns
Laser Current Turn-Off Delay	max. 10 ns

### Current Control

Current from LDA	max. 320 mA
Resistor at RSI	0.78 to 9 kOhm
Overcurrent Reset Delay	max. 10 µs

### Safety Monitor Diode

Reset Delay	max. 210 ns
-------------	-------------

## Pin Configuration QFN28 4 x 4 mm<sup>2</sup>

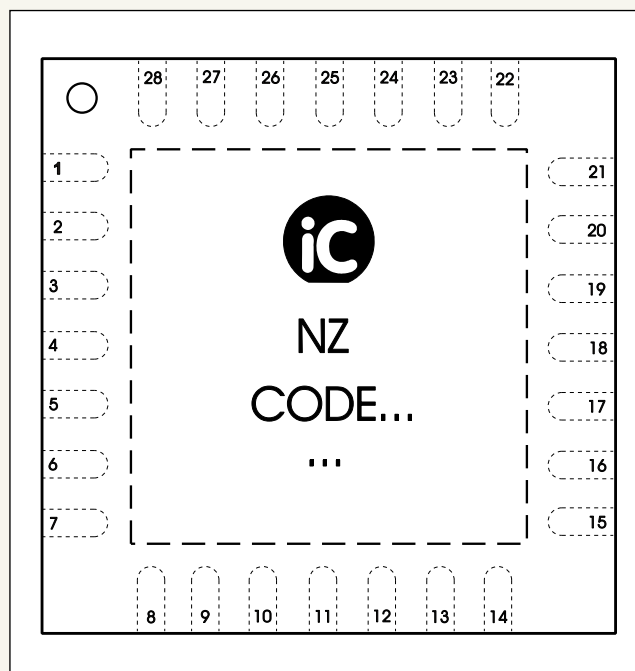

This tentative information shall not be considered as a guarantee of characteristics. Rights to technical changes reserved.