

# iC-LG

## 21-BIT OPTICAL POSITION ENCODER WITH SERIAL/PARALLEL AND SIN/COS OUTPUT



iC-LG is an optoelectronic encoder IC for absolute linear or angular measuring systems, such as glass scales and shaft encoders. Photosensors, amplifiers and comparators, the entire signal conditioning unit and interfaces for the position data output are monolithically integrated on the chip.

### Applications

- Optical high-resolution absolute position encoders
- Analog and digital moto feedback systems
- Robotics, tooling machines, servo motors

### Features

- Excellent matching and reliability granted by system-on-chip design with integrated photosensors
- Differential track evaluation and signal-related hysteresis comparators grant EMI immunity and operation up to 125 °C
- High assembly tolerance due to synchronized scanning principle using pre- and post-positioned photosensors
- 13 digital tracks pitched at just 500 µm
- 2 sine/cosine analog tracks with enlarged photosensors and electronic calibration features
- Position data resolution of 16 to 21 bits by on-chip interpolation (by 3-bit flash or 8-bit S&H ADC)
- Services external multturn encoders and interpolation ICs
- LED power control with a 50 mA highside driver
- Adjustable on-chip temperature sensor with a min/max alarm
- Operational monitoring with alarm output for missing code, corrupted single/multturn data (disc error), EEPROM link error, illumination error (end of life), out-of-range temperature
- Interface modes: parallel encoder, serial BiSS/SSI, µC
- 4 to 5.5 V single supply operation, low power consumption
- Options: extended temperature range of -40 to +125 °C, customized COB assemblies, reticles and code discs

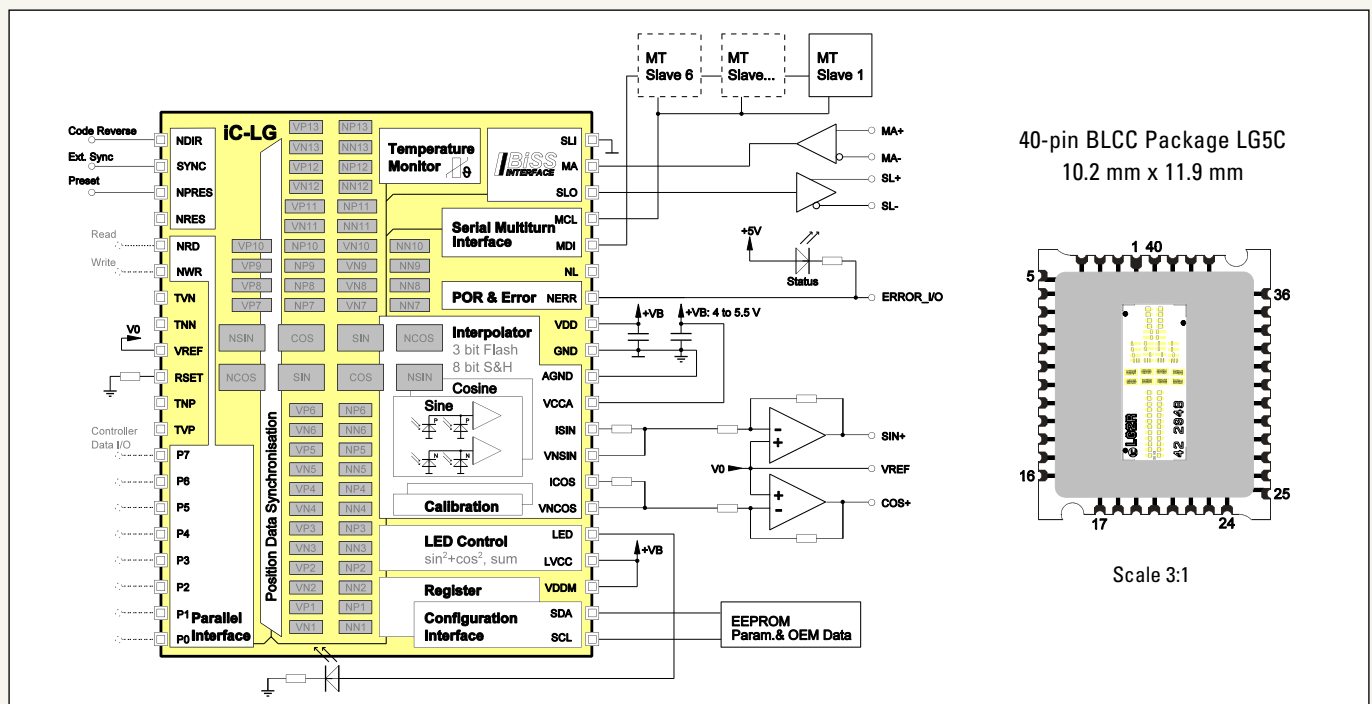

# iC-LG 21-BIT OPTICAL POSITION ENCODER

The differential evaluation of all tracks enables operation at high ambient temperatures. Scanning uses pre- and post-positioned photosensors for each track, permitting high adjustment tolerances during system assembly. An integrated LED power control with a highside driver guarantees illumination regardless of temperature or aging effects.

The chip features offset and amplitude calibration for the analog output signals also fed to the integrated 3-bit flash and the 8-bit SAR interpolators.

External multiturn sensor slaves can be operated via an SSI interface. Here, iC-LG is master and synchronizes all data to produce a contiguous, single-step-proof position data word. Additionally, temperature data is available from an on-chip sensor, featuring adjustable high/low alarms to monitor encoder and drive operation.

The fast BiSS interface (SSI mode is optional) and an 8-bit microcontroller interface are available to output the position data and to configure the chip. An external EEPROM can also provide setup and OEM data.

## Pin Functions

No.	BiSS Name	$\mu$ C Name	PAR Name	Interface Mode	Pin Function
1	NDIR				Reversal of Rotation Dir. Input
2	SYNC		D(10)		Synch. Input / Parallel Data Output
3	NPRES				Preset Input / Alignment Mode Enable
4	NRES				Reset Input / Reset Active Message
5		NRD	D(9)		Read Signal / Par. Data Output
6		NWR	D(8)		Write Signal / Par. Data Output
9	VREF				+2.5 V Reference Voltage Output
10	RSET				LED Power Control Adjustment
13...20		P(7...0)	D(7...0)		Data Bus $\mu$ C / Par. Data Output
21	SCL				Clock Output, Configuration Interface
22	SDA				Data Line, Configuration Interface
23	VDDM				+5 V Multiturn Functions Supply Voltage
24	LVCC				+5 V LED Driver Supply Voltage
25	LED				LED Current Source Output
26	VNCOS				Cosine Voltage Output (inverted) (Alignment Mode: Voltage Output D0)
27	ICOS				Cosine Current Output
28	VNSIN				Sine Voltage Output (inverted) (Alignment Mode: Voltage Output D1)
29	ISIN				Sine Current Output
30	VCCA				+5 V Analog Supply Voltage
31	AGND				Analog Ground
32	GND				Digital Ground
33	VDD				+5 V Digital Supply Voltage
34	NERR				Error Message I/O
35			NL		Output Latch Enable Input
36	MDI				Data Input, Multiturn Interface
37	MCL		D14		Clock Output, Multit. / Par. Data Output
38	SLO		D13		Data Output, BiSS / Par. Data Output (Alignment M.: V1 xor V13, Test M.: TP)
39	MA		D12		Clock Input, BiSS / Par. Data Output
40	SLI		D11		Data Input, BiSS / Par. Data Output
7, 8, 11, 12					Test Mode Current Input

## Key Specifications

General	
Supply Voltage	single 4 V to 5.5 V
Supply Current	typ. 10 mA
On-Chip Oscillator	5 MHz
LED Power Control	50 mA max. (highside current source output)
ESD Susceptibility	2 kV (HBM 100 pF, 1.5 k $\Omega$ )
Operational Temperature Range	-20 °C to +90 °C (-40 °C to +125 °C optional)
Chip Size	3.5 mm x 7 mm
Packages	40-pin BLCC LG5C (10.2 x 11.9 x 1.7 mm) smaller optoBGA package on request
Options	on-chip reticle, code discs

Position Acquisition	
Max. Singleturn Resolution	21 bits / 360° (extendable by consecutive electronics)
Max. Multiturn Resolution	24 bits
Angle Resolution (disc LG2S)	11+3 bits, 11+8 bits (524,288 CPT)
Absolute Angle Accuracy	+/- 1 LSB @ 19 bits (mounted within 0.7 DEG tilt angle)
Max. Operating Speed	12,000 RPM

Temperature Monitoring	
Range, Resolution	-64 °C to +191 °C, resolution 1 °C (LSB)
Alarm Output	adjustable high/low alarm thresholds

Data I/O	
BiSS Interface	serial two-wire link, triggered position capture, data rate of up to 15 Mbit/s (SSI mode: 4 Mbit/s)
$\mu$ C Interface	8-bit data bus, 1 MHz access cycle per byte
Multiturn Sensor Interface	SSI, 200 kbit/s, 12+1 to 24+1 bit, binary coded (single word) or Gray coded (3 to 6 words)
Analog Outputs	sine/cosine wave output to 500 kHz, 0.5 Vpp calibrated
Serial EEPROM	100 kbit/s, compatible with I2C, 1 to 16 kbits

RAM	
Position Data	3 bytes for singleturn (with interpolation), 3 bytes for multiturn
Temperature Data	1 byte
Calibration Data	5 bytes (analog signals and temperature sensor calibration)
Configuration Data	27 bytes for configuration, 8 bytes for device ID

Operational Functions	
Device Configuration	via EEPROM, BiSS, $\mu$ C Interface
Parameterization	resolution, disc model, multiturn functions, output code format, sense of rotation, alarm messages
Position Preset	selectable by pin, BiSS, $\mu$ C Interface
Monitoring & Alarm	missing code, corrupted single/multiturn data (disc error), EEPROM link error, illumination error (end of life), out-of-range temperature
Test Modes	analog sensor stimulation
Alignment Modes	radial position and tilt angle alignment aids