

iC-DN

LOWSIDE SWITCH

FEATURES

- ◆ 36 V lowside switch/level shifter
- ◆ Decoupling of input and output reference voltages (SOT23-6L) permits control by 5V logic
- ◆ 200 mA of output current
- ◆ Short-circuit protected
- ◆ Output with an active freewheeling circuit
- ◆ On-chip over-temperature protection with hysteresis
- ◆ 4 to 36 V input voltage range
- ◆ Input with hysteresis
- ◆ 3-pin configuration possible
- ◆ Wide temperature range of -40 to 120 °C
- ◆ Package option on request: (SC59-3L, CSP, DFN)

APPLICATIONS

- ◆ Lowside switch for industrial applications, such as relays, inductive proximity sensors and light barriers

PACKAGES

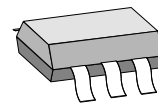

SOT23-6L

BLOCK DIAGRAM

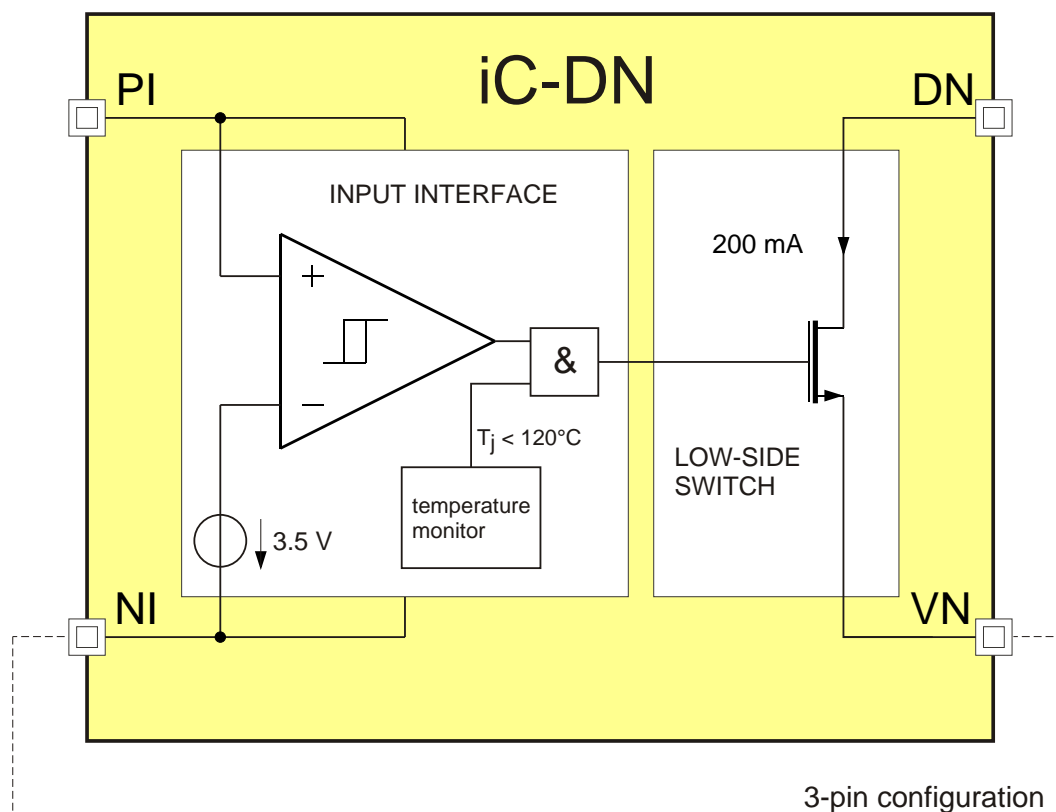

iC-DN

LOWSIDE SWITCH

DESCRIPTION

iC-DN is a monolithic lowside switch for ohmic, inductive and capacitive loads.

Designed for a wide input voltage range of 4 to 36 V, it is capable of supplying a minimum output current of 200 mA. The output acts as a current source with a low saturation voltage; protection against short-circuiting is provided by the device shutting down with

excessive temperature. The chip is activated when the input voltage threshold $V(\text{PI})-V(\text{NI})$ of typically 3.5 V is exceeded.

With four leads, the input (PI, NI) and output (DN, VN) reference voltages are decoupled. The maximum permissible voltage difference between NI and VN is 36 V.

PACKAGES SOT23-6L (JEDEC)

PIN CONFIGURATION
SOT23-6L (JEDEC), 1.6 mm
(top view)

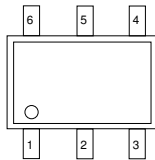

PIN FUNCTIONS
No. Name Function

1	n.c.	
2	VN	Ground, Substrate
3	NI	Input Reference Voltage
4	n.c.	
5	PI	Positive Input, Supply
6	DN	Output

SC59-3L, DFN and CSP packages available on request.

ABSOLUTE MAXIMUM RATINGS

Beyond these values damage may occur; device operation is not guaranteed. Absolute Maximum Ratings are no Operating Conditions. Integrated circuits with system interfaces, e.g. via cable accessible pins (I/O pins, line drivers) are per principle endangered by injected interferences, which may compromise the function or durability. The robustness of the devices has to be verified by the user during system development with regards to applying standards and ensured where necessary by additional protective circuitry. By the manufacturer suggested protective circuitry is for information only and given without responsibility and has to be verified within the actual system with respect to actual interferences.

Item No.	Symbol	Parameter	Conditions	Fig.	Limits		Unit
					Min.	Max.	
G001	V()	PI, NI Input Voltage with reference to VN	$V() = V(PI) - V(VN)$ or $V() = V(NI) - V(VN)$		-0.3	40	V
G002	V(DN)	DN Output Voltage	no free wheeling		-0.3	40	V
G003	I(DN)	DN Output Current				300	mA
G004	I(PI)	PI Input Current				10	mA
G005	I(NI)	NI Input Current			-10		mA
G006	Vd()	ESD Susceptibility	HBM 100 pF discharged through 1.5 kΩ			2	kV
G007	Tj	Max. Junction Temperature			-40	150	°C
G008	Ts	Storage Temperature Range			-40	150	°C
G009	Eas	Inductive load switch-off energy dissipation	temperature monitor not active, $T_j < T_{on}$			5	mJ

THERMAL DATA

Operating Conditions: $V(PI) = 4...36 V$, unless otherwise stated

Item No.	Symbol	Parameter	Conditions	Fig.	Limits			Unit
					Min.	Typ.	Max.	
T01	Ta	Ambient Temperature Range			-40		120	°C

iC-DN

LOWSIDE SWITCH

ELECTRICAL CHARACTERISTICS

Operating Conditions: $V(PI) = 4...36\text{ V}$, $T_j = -40...120\text{ °C}$, unless otherwise stated

Item No.	Symbol	Parameter	Conditions	Tj °C	Fig.				Unit
						Min.	Typ.	Max.	
Total Device									
001	V(PI)	PI Supply Voltage with reference to VN				4		36	V
002	I(PI)	PI Supply Current	No load; $(V(PI) - V(NI)) > V(PI)_{on}$ (301) $(V(PI) - V(NI)) < V(PI)_{off}$ (302)			250 0		950 750	μA μA
003	I(NI)	NI Input Current	No load; $(V(PI) - V(NI)) > V(PI)_{on}$ $(V(PI) - V(NI)) < V(PI)_{off}$			-500 -200		20 0	μA μA
004	I(VN)	VN Supply Current	No load; $(V(PI) - V(NI)) > V(PI)_{on}$ $(V(PI) - V(NI)) < V(PI)_{off}$			-650 -600		-200 0	μA μA
005	Ilk(DN)	DN Output Leakage Current	$(V(PI) - V(NI)) < V(PI)_{off}$, $V(DN) = 0...36\text{ V}$			-100		100	μA
006	Vc(DN)hi	DN Clamp Voltage high	$Vc(DN)_{hi} = V(DN) - V(VN)$, $I(DN) = 10\text{ mA}$			40	45	60	V
007	Vc(DN)lo	DN Clamp Voltage low	$Vc(DN)_{lo} = V(DN) - V(VN)$, $I(DN) = -10\text{ mA}$			-1		-0.3	V
008	Vc(j)hi	PI, NI Clamp Voltage high	$Vc(j)_{hi} = V(j) - V(VN)$, $I(j) = 4\text{ mA}$			37	40		V
009	Vc(j)lo	PI, NI Clamp Voltage low	$Vc(j)_{lo} = V(j) - V(VN)$, $I(j) = -4\text{ mA}$			-1		-0.3	V
010	tpiohi	Activation Delay PI → DN	$V(PI)_{on} < (V(PI) - V(NI)) < 36\text{ V}$, $V(Rload) = 36\text{ V}$, $Rload = 360\ \Omega$, $I(DN) = 0 \rightarrow 90\text{ mA}$			0.6		6	μs
011	tpiolo	Deactivation Delay PI → DN	$(V(PI) - V(NI)) < V(PI)_{off}$, $V(Rload) = 36\text{ V}$, $Rload = 360\ \Omega$, $I(DN) = 100 \rightarrow 10\text{ mA}$			0.6		35	μs
Lowside Output DN									
101	Vs(DN)	Output Saturation Voltage	DN = lo; $I(DN) = 200\text{ mA}$ $I(DN) = 50\text{ mA}$					600 150	mV mV
102	Isc(DN)	Output Short-Circuit Current	$V(DN) = 1\text{ V}...V_B$, DN = lo			200	300	550	mA
103	SR(DN)on	Slew Rate $V(DN) \rightarrow 0$	$(V(PI) - V(NI)) > V(PI)_{on}$, $V(Rload) = 36\text{ V}$, $Rload = 360\ \Omega$, $V(DN) = 32.4 \rightarrow 3.6\text{ V}$				65		V/ μs
104	SR(DN)off	Slew Rate $V(DN) \rightarrow V(PI)$	$(V(PI) - V(NI)) < V(PI)_{off}$, $V(Rload) = 36\text{ V}$, $Rload = 360\ \Omega$, $V(DN) = 3.6 \rightarrow 32.4\text{ V}$				20		V/ μs
105	Vfw(DN)	Freewheeling Voltage	$I(DN) = 200\text{ mA}$			40	45	60	V
Temperature Monitor									
201	Toff	Thermal Shutdown Threshold				120		150	°C
202	Ton	Thermal Release Threshold	Decreasing temperature			110		135	°C
203	Thys	Thermal Shutdown Hysteresis	$Thys = Toff - Ton$				15		°C
Input Threshold									
301	V(PI)on	Power-On Threshold Voltage $V(PI) - V(NI)$				2.7		4.3	V
302	V(PI)off	Power-Off Threshold Voltage $V(PI) - V(NI)$	Decreasing voltage			1.7		3.9	V
303	V(PI)hys	Hysteresis	$V(PI)_{hys} = V(PI)_{on} - V(PI)_{off}$			160	250	1200	mV

ELECTRICAL CHARACTERISTIC: DIAGRAMS

Simulation Data

(current consumption without load; leakage currents not included)

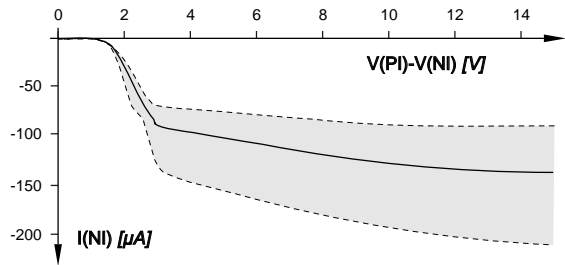

Figure 1: NI input current, load independent

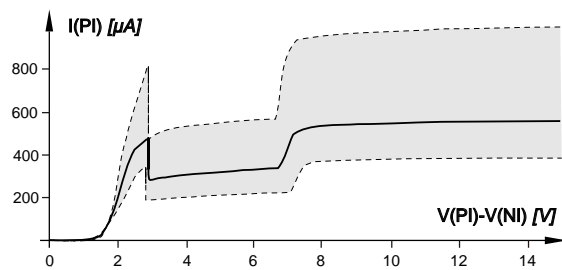

Figure 2: PI input current, no load

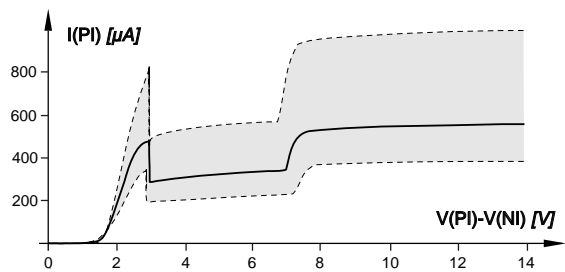

Figure 3: PI input current, $I(\text{DN}) = 5 \text{ mA}$

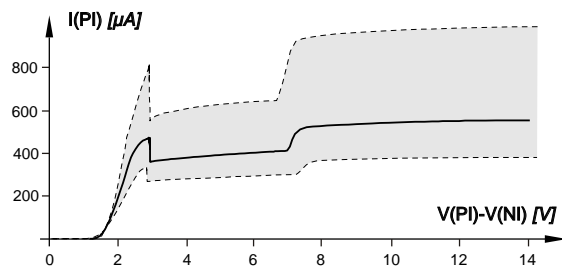

Figure 4: PI input current, $I(\text{DN}) = 100 \text{ mA}$

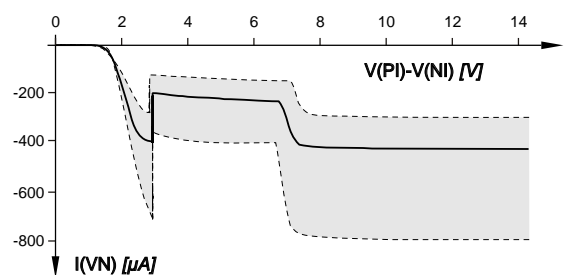

Figure 5: VN supply current

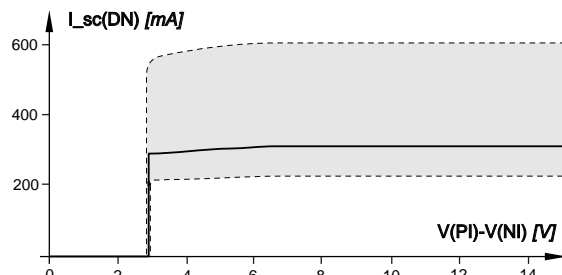

Figure 6: DN short-circuit output current

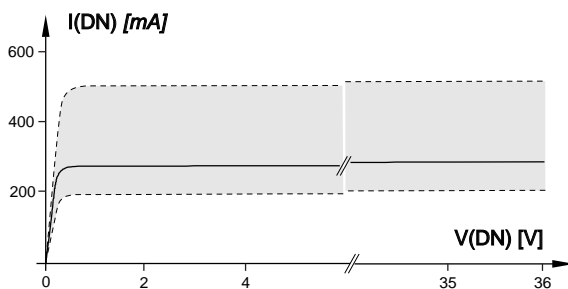

Figure 7: DN output characteristic

APPLICATION NOTES

Example application circuits

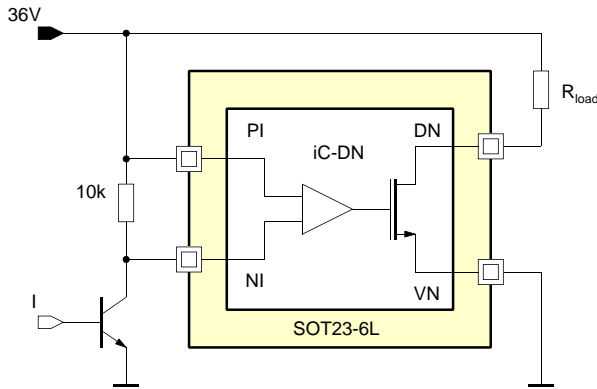

Figure 8: 36 V supply, NPN input control

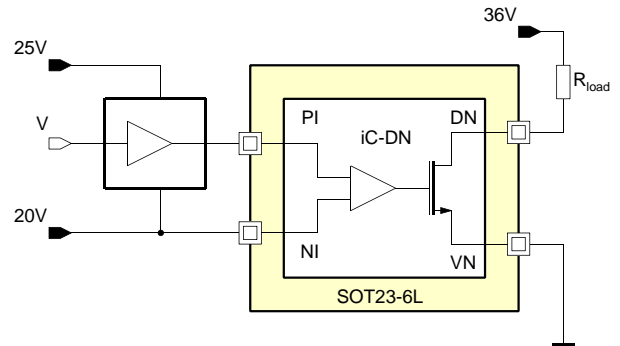

Figure 9: 5 V μ C operation at 20 to 25 V input control, 36 V output supply

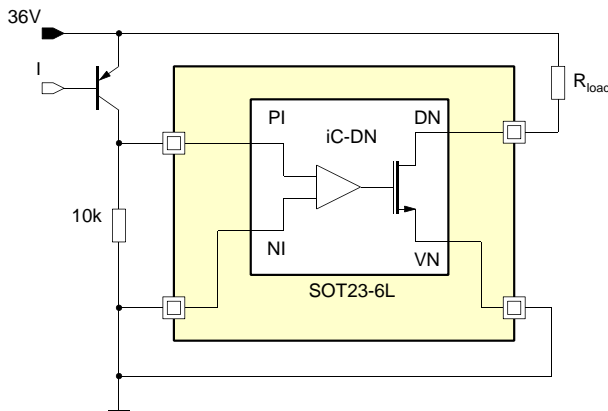

Figure 10: 36 V supply, PNP input control

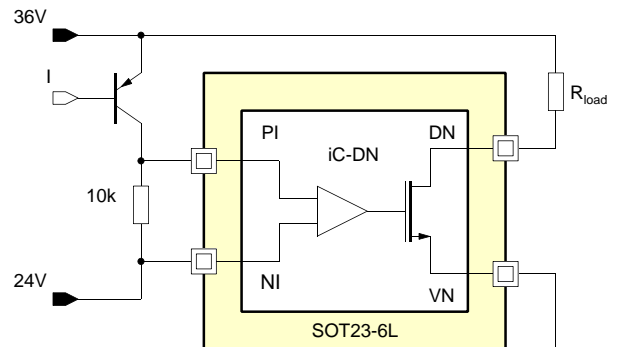

Figure 11: 12 V PNP input control, 36 V supply

This specification is for a newly developed product. iC-Haus therefore reserves the right to change or update, without notice, any information contained herein, design and specification; and to discontinue or limit production or distribution of any product versions. Please contact iC-Haus to ascertain the current data. Copying – even as an excerpt – is only permitted with iC-Haus approval in writing and precise reference to source.

iC-Haus does not warrant the accuracy, completeness or timeliness of the specification on this site and does not assume liability for any errors or omissions in the materials. The data specified is intended solely for the purpose of product description. No representations or warranties, either express or implied, of merchantability, fitness for a particular purpose or of any other nature are made hereunder with respect to information/specification or the products to which information refers and no guarantee with respect to compliance to the intended use is given. In particular, this also applies to the stated possible applications or areas of applications of the product.

iC-Haus conveys no patent, copyright, mask work right or other trade mark right to this product. iC-Haus assumes no liability for any patent and/or other trade mark rights of a third party resulting from processing or handling of the product and/or any other use of the product.

iC-DN

LOWSIDE SWITCH

preliminary



Rev B1, Page 7/7

ORDERING INFORMATION

Type	Package	Order Designation
iC-DN	SOT23-6L (JEDEC)	iC-DN SOT23-6L

For technical support, information about prices and terms of delivery please contact:

iC-Haus GmbH
Am Kuemmerling 18
D-55294 Bodenheim
GERMANY

Tel.: +49 (61 35) 92 92-0
Fax: +49 (61 35) 92 92-192
Web: <http://www.ichaus.com>
E-Mail: sales@ichaus.com

Appointed local distributors: http://www.ichaus.de/support_distributors.php