

iC-BM FOUR-CHANNEL FOUR-QUADRANT ANALOG MULTIPLIER



Rev A2, Page 1/7

FEATURES

MLT04 replacement
 Four independent channels
 Four-quadrant multiplication
 Voltage output: $W = 0.4 \times X \times Y$
 ± 2.5 V analog input range
 3.5 MHz bandwidth
 Low power dissipation

APPLICATIONS

Analog computation
 Squaring circuits
 Modulation and demodulation
 Voltage controlled amplifiers and filters

PACKAGES

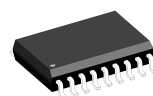

SO18W
 (RoHS compliant)

BLOCK DIAGRAM

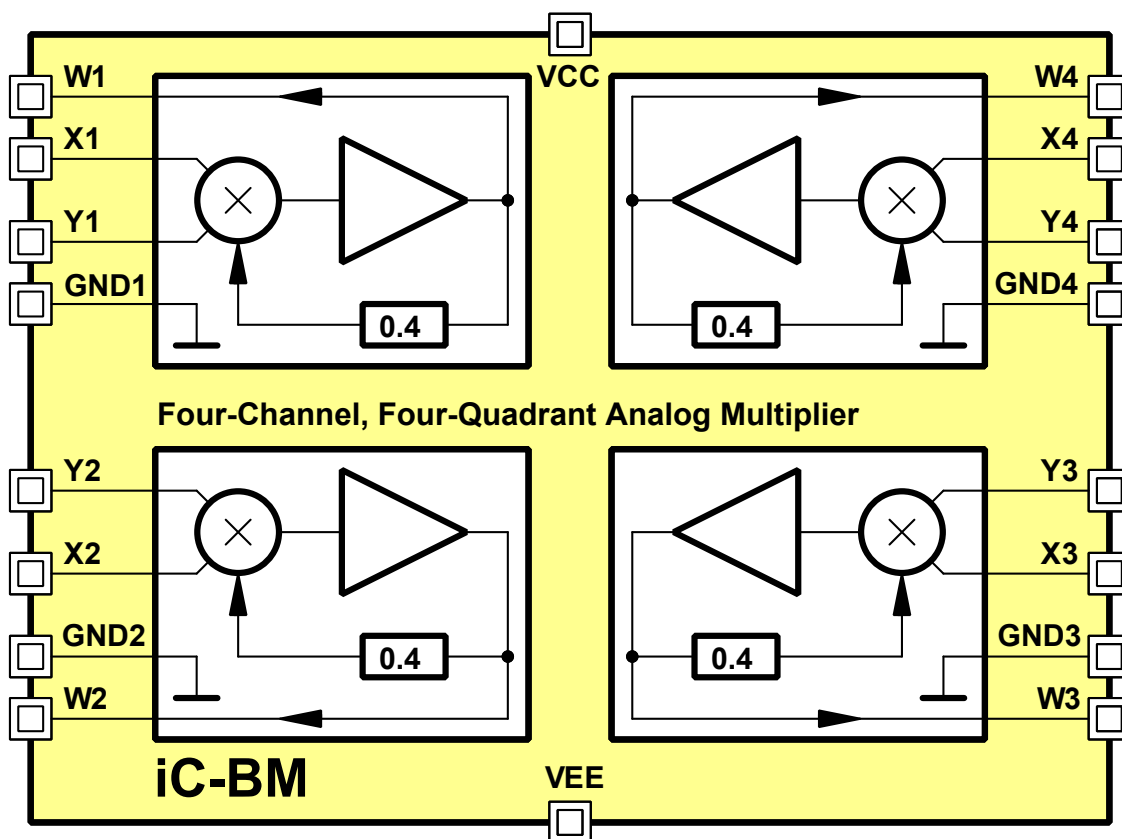

iC-BM FOUR-CHANNEL FOUR-QUADRANT ANALOG MULTIPLIER



Rev A2, Page 2/7

DESCRIPTION

iC-BM features four analog multipliers. Each four-quadrant multiplier consists of a Gilbert cell multiplier with a 0.4 scale factor, a linearisation circuit and a unity gain output amplifier.

For higher precision all internal bias currents are derived from an internal band-gap reference.

All pins are ESD protected.

PACKAGES

PIN CONFIGURATION SO18W

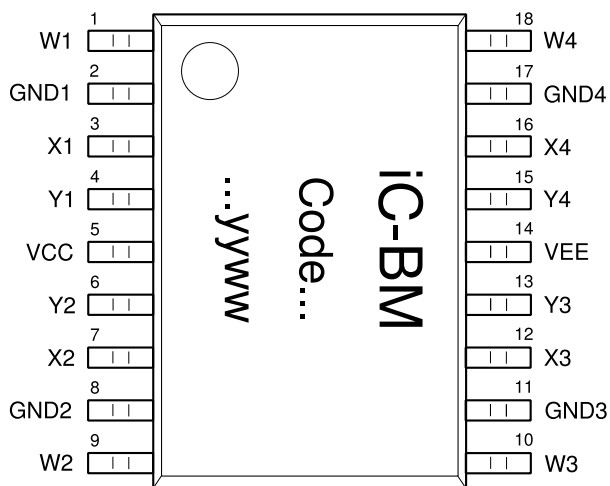

PIN FUNCTIONS

No. Name Function

1	W1	Channel 1: Analog multiplier output
2	GND1	Channel 1: Ground
3	X1	Channel 1: First input of multiplier
4	Y1	Channel 1: Second input of multiplier
5	VCC	Positive power supply +5 V
6	Y2	Channel 2: Second input of multiplier
7	X2	Channel 2: First input of multiplier
8	GND2	Channel 2: Ground
9	W2	Channel 2: Analog multiplier output
10	W3	Channel 3: Analog multiplier output
11	GND3	Channel 3: Ground
12	X3	Channel 3: First input of multiplier
13	Y3	Channel 3: Second input of multiplier
14	VEE	Negative power supply -5 V
15	Y4	Channel 4: Second input of multiplier
16	X4	Channel 4: First input of multiplier
17	GND4	Channel 4: Ground
18	W4	Channel 4: Analog multiplier output

iC-BM FOUR-CHANNEL FOUR-QUADRANT ANALOG MULTIPLIER



Rev A2, Page 3/7

PACKAGE DIMENSIONS SO18W

SIDE

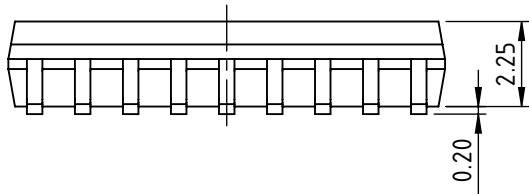

FRONT

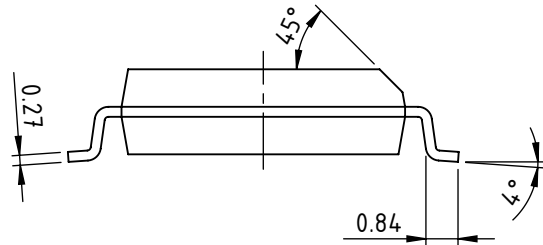

TOP

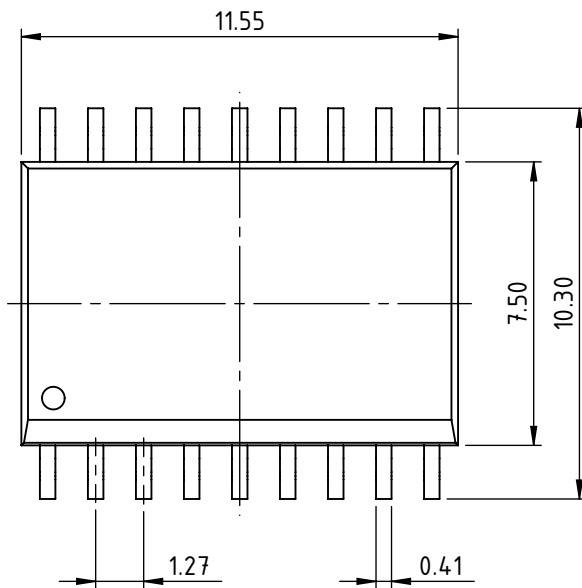

RECOMMENDED PCB-FOOTPRINT

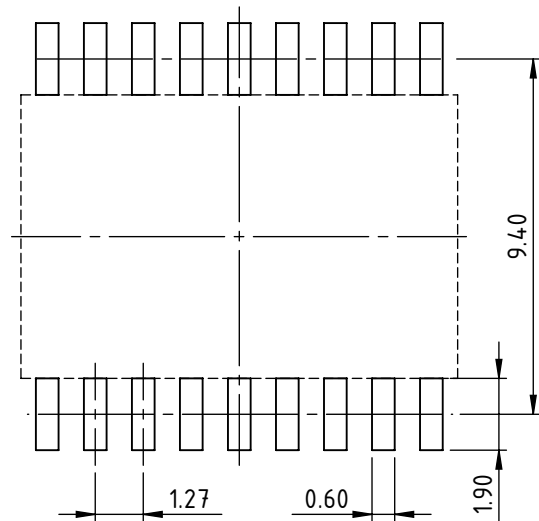

dra_so18w-1_pack_1, 5:1

iC-BM FOUR-CHANNEL FOUR-QUADRANT ANALOG MULTIPLIER



Rev A2, Page 4/7

ABSOLUTE MAXIMUM RATINGS

Beyond these values damage may occur; device operation is not guaranteed.

Item No.	Symbol	Parameter	Conditions			Unit
				Min.	Max.	
G001	VCC	Positive Power Supply			7	V
G002	VEE	Negative Power Supply		-7		V
G003	V()	Voltage at Pins X _{1...4} , Y _{1...4} and W _{1...4}		-7	7	V
G004	T _j	Chip Temperature		-40	150	°C
G005	T _s	Storage Temperature		-40	150	°C

THERMAL DATA

Operating Conditions: VCC = 5 V ±0.25 V , VEE = -5 V ±0.25 V, T_j = -40...100 °C, R_L = 2 kΩ, if not other specified

Item No.	Symbol	Parameter	Conditions				Unit
				Min.	Typ.	Max.	
T01	T _a	Operating Ambient Temperature Range		-40		85	°C
T02	R _{thja}	Thermal Resistance Chip/Ambient			68		K/W

All voltages are referenced to ground unless otherwise stated.

All currents flowing into the device pins are positive; all currents flowing out of the device pins are negative.

iC-BM FOUR-CHANNEL FOUR-QUADRANT ANALOG MULTIPLIER



Rev A2, Page 5/7

ELECTRICAL CHARACTERISTICS

Operating Conditions: $V_{CC} = 5\text{ V} \pm 0.25\text{ V}$, $V_{EE} = -5\text{ V} \pm 0.25\text{ V}$, $T_j = -40\text{...}100\text{ }^\circ\text{C}$, $R_L = 2\text{ k}\Omega$, if not other specified

Item No.	Symbol	Parameter	Conditions	Min.	Typ.	Max.	Unit
General							
101	V(VCC)	Positive Supply Voltage Range		4.75	5	5.25	V
102	V(VEE)	Negative Supply Voltage Range		-5.25	-5	-4.75	V
103	I(VCC)	Positive Supply Current	$W_{1...4}$ without load resistors		15	20	mA
104	I(VEE)	Negative Supply Current	$W_{1...4}$ without load resistors	-20	-15		mA
105	P_{DISS}	Power Dissipation	$P_{DISS} = 5\text{ V} \times I_{CC} + 5\text{ V} \times I_{EE}$		150	200	mW
Multiplier Performance							
201	$V(X_{1...4})_{os}$	Offset Voltage $X_{1...4}$	$V(X_{1...4}) = 0\text{ V}$, $V(Y_{1...4}) = \pm 2.5\text{ V}$	-50		50	mV
202	$V(Y_{1...4})_{os}$	Offset Voltage $Y_{1...4}$	$V(Y_{1...4}) = 0\text{ V}$, $V(X_{1...4}) = \pm 2.5\text{ V}$	-50		50	mV
203	$V(W_{1...4})_{os}$	Output Offset Voltage $W_{1...4}$	$V(X_{1...4}) = 0\text{ V}$, $V(Y_{1...4}) = 0\text{ V}$	-50		50	mV
204	$TCV()_{os}$	Output Offset Drift $W_{1...4}$	$V(X_{1...4}) = 0\text{ V}$, $V(Y_{1...4}) = 0\text{ V}$		50		$\mu\text{V}/^\circ\text{C}$
205	K	Fix Scale Factor	$V(X_{1...4}) = \pm 2.5\text{ V}$, $V(Y_{1...4}) = \pm 2.5\text{ V}$	0.38	0.4	0.42	1/V
206	$TE(X_{1...4})$	Total Error $X_{1...4}$	$-2.5\text{ V} \leq X \leq 2.5\text{ V}$, $Y = 2.5\text{ V}$, measured as % of the $\pm 2.5\text{ V}$ full scale	-5	± 2	5	%
207	$TE(Y_{1...4})$	Total Error $Y_{1...4}$	$-2.5\text{ V} \leq Y \leq 2.5\text{ V}$, $X = 2.5\text{ V}$, measured as % of the $\pm 2.5\text{ V}$ full scale	-5	± 2	5	%
208	$TCE(X_{1...4})$	Total Error Drift $X_{1...4}$	$V(X_{1...4}) = -2.5\text{ V}$, $V(Y_{1...4}) = 2.5\text{ V}$		0.005		$\%/^\circ\text{C}$
209	$TCE(Y_{1...4})$	Total Error Drift $Y_{1...4}$	$V(Y_{1...4}) = -2.5\text{ V}$, $V(X_{1...4}) = 2.5\text{ V}$		0.005		$\%/^\circ\text{C}$
210	SE()	Total Square Error $X_{1...4}$, $Y_{1...4}$	$V(X_1) = V(Y_1)$, $V(X_2) = V(Y_2)$, $V(X_3) = V(Y_3)$ and $V(X_4) = V(Y_4)$		5		%
211	$LE(X_{1...4})$	Linearity Error $X_{1...4}$	$-2.5\text{ V} \leq X \leq 2.5\text{ V}$, $Y = 2.5\text{ V}$	-1	± 0.2	1	%
212	$LE(Y_{1...4})$	Linearity Error $Y_{1...4}$	$-2.5\text{ V} \leq Y \leq 2.5\text{ V}$, $X = 2.5\text{ V}$	-1	± 0.2	1	%
Dynamic Performance							
301	BW	Small Signal Bandwidth	$V(W_{1...4}) = 0.1\text{ V}_{rms}$		3.5		MHz
302	SR	Slew Rate	$V(W_{1...4}) = \pm 2.5\text{ V}$		30		V/ μs
303	t_s	Settling Time	$V(W_{1...4}) = \Delta 2.5\text{ V}$ and 1% error band		1		μs
304	FT_{AC}	AC Feedthrough	$V(X_{1...4}) = 0\text{ V}$, $V(Y_{1...4}) = 1\text{ V}_{rms}$ and $f = 1\text{ kHz}$		-65		dB
305	CT_{AC}	Crosstalk	$V(X_{1...4}) = V(Y_{1...4}) = 1\text{ V}_{rms}$, $f = 100\text{ kHz}$, applied to adjacent channel		-90		dB
Outputs: $W_{1...4}$							
401	Isc()	Short Circuit Current			± 30		mA
402	$THD(X_{1...4})$	Total Harmonic Distortion $X_{1...4}$	$f = 1\text{ kHz}$, $V(Y_{1...4}) = 2.5\text{ V}$		0.1		%
403	$THD(Y_{1...4})$	Total Harmonic Distortion $Y_{1...4}$	$f = 1\text{ kHz}$, $V(X_{1...4}) = 2.5\text{ V}$		0.02		%
404	PSSR()	Power Supply Sensitivity Ratio	$V(X_{1...4}) = V(Y_{1...4}) = 0\text{ V}$, $V_{CC} = \Delta 5\%$ or $V_{EE} = \Delta 5\%$			10	mV/V
405	EN_A	Audio Band Noise	$BW = 10\text{ Hz to }50\text{ kHz}$		70		μV_{rms}
406	EN_W	Wide Band Noise	$BW = 1.9\text{ MHz}$		590		μV_{rms}
407	en	Spot Noise Voltage	Noise at $f = 1\text{ kHz}$		0.3		$\mu\text{V}/\sqrt{\text{Hz}}$
Inputs: $X_{1...4}$, $Y_{1...4}$							
501	VR()in	Analog Input Range	$V(GND_{1...4}) = 0\text{ V}$	-2.5		2.5	V
502	I()in	Input Current	$V(X_{1...4}) = V(Y_{1...4}) = 0\text{ V}$		2.3	10	μA
503	R()in	Input Resistance			1		M Ω
504	C()in	Input Capacitance			3		pF

iC-BM FOUR-CHANNEL FOUR-QUADRANT ANALOG MULTIPLIER



Rev A2, Page 6/7

iC-Haus expressly reserves the right to change its products and/or specifications. An info letter gives details as to any amendments and additions made to the relevant current specifications on our internet website www.ichaus.de/infoletter; this letter is generated automatically and shall be sent to registered users by email.

Copying – even as an excerpt – is only permitted with iC-Haus' approval in writing and precise reference to source.

iC-Haus does not warrant the accuracy, completeness or timeliness of the specification and does not assume liability for any errors or omissions in these materials.

The data specified is intended solely for the purpose of product description. No representations or warranties, either express or implied, of merchantability, fitness for a particular purpose or of any other nature are made hereunder with respect to information/specification or the products to which information refers and no guarantee with respect to compliance to the intended use is given. In particular, this also applies to the stated possible applications or areas of applications of the product.

iC-Haus conveys no patent, copyright, mask work right or other trade mark right to this product. iC-Haus assumes no liability for any patent and/or other trade mark rights of a third party resulting from processing or handling of the product and/or any other use of the product.

As a general rule our developments, IPs, principle circuitry and range of Integrated Circuits are suitable and specifically designed for appropriate use in technical applications, such as in devices, systems and any kind of technical equipment, in so far as they do not infringe existing patent rights. In principle the range of use is limitless in a technical sense and refers to the products listed in the inventory of goods compiled for the 2008 and following export trade statistics issued annually by the Bureau of Statistics in Wiesbaden, for example, or to any product in the product catalogue published for the 2007 and following exhibitions in Hanover (Hannover-Messe).

We understand suitable application of our published designs to be state-of-the-art technology which can no longer be classed as inventive under the stipulations of patent law. Our explicit application notes are to be treated only as mere examples of the many possible and extremely advantageous uses our products can be put to.

iC-BM FOUR-CHANNEL FOUR-QUADRANT ANALOG MULTIPLIER



Rev A2, Page 7/7

ORDERING INFORMATION

Type	Package	Order Designation
iC-BM	SO18W	iC-BM SO18W

For technical support, information about prices and terms of delivery please contact:

iC-Haus GmbH
Am Kuemmerling 18
D-55294 Bodenheim
GERMANY

Tel.: +49 (61 35) 92 92-0
Fax: +49 (61 35) 92 92-192
Web: <http://www.ichaus.com>
E-Mail: sales@ichaus.com

Appointed local distributors: http://www.ichaus.com/sales_partners